



Germaniastraße 28
D 44379 Dortmund
Telefon: +49 (0)231/61009-0
E-mail: gefa@gefa.com

Postfach 700110
D 44371 Dortmund
Fax: +49 (0)231/61009-80
Internet: www.gefa.com

Instructions for use

DOMINO valves

AT 100 / 150 / 200 / 300 / 400 / 600

Instructions for use

Transport, storage, recommendations for installation and instructions for initial operation of DOMINO valves

Valves with compact transverse seal

Series AT 100 / 150 / 200 / 300 / 400 / 600

1. Transport

2. Storage

3. Installation

- 3.1 Safety recommendations
- 3.2 Removal of additional corrosion preventative
- 3.3 Preservation of EKB (epoxy powder coating) and special painting
- 3.4 Protection of the valve
- 3.5 Place of installation
- 3.6 Position of installation
- 3.7 Direction of flow

4. Mounting

5. Initial operation

- 5.1 General measures
- 5.2 Shutting off powdery or granular media
- 5.3 Control pressure / use of control media
- 5.4 Pneumatically-operated valves
- 5.5 Hydraulically-operated valves
- 5.6 Electrically-operated valves
- 5.7 Bitumen valves

6. Recommendations for the maintenance of DOMINO valves

- 6.1 Readjusting the seal
- 6.2 Minor leaks
- 6.3 Lubrication of valves
- 6.4 Cleaning

7. Final remarks

Transport, storage, recommendations for installation and instructions for initial operation of DOMINO valves

1. Transport

- 1.1 The transportation of the valves to their final destination (building site) must be done in a solid box adapted to the size of the valve taking into account the type of transport as well as any applicable regulations.
- 1.2 The valves must be suitably protected against external damage and atmospheric effects.
- 1.3 Depending on the duration of transportation and storage and also with regard to the climatic conditions, preservation must be made by means of gas treatment or by shrink-wrapping and sealing the valve in polyethylene film that also has an adequate amount of a desiccant such as silica gel placed inside.

2. Storage

- 2.1 The valves should be stored indoors in a dry place until final installation. All working parts must be suitably covered to protect them against humidity, dust or other soiling.
- 2.2 During a longer period of storage or in the case of unfavourable storage conditions that might affect subsequent functioning, all metallic bright surfaces such as the spindle, piston rod, and sealing surfaces must be effectively protected against corrosion by means of a suitable and durable corrosion preventative.
- 2.3 The corrosion preventative applied at the factory must be checked for any damage in transit and suitably repaired if needed.
- 2.4 For parts mounted on the valves, such as electrical actuators, limit switches, valves, etc., the corresponding storage instructions of the relevant manufacturers shall have priority.

3. Installation

3.1 Safety recommendations

Operation of electrically, pneumatically, or hydraulically-operated valves that have not yet been installed is not permitted. Warning: danger of accidents!

Protective device

Removal of the protective cover, except for installation, maintenance and / or repair work, is not permitted. After dismantling the protective cover to carry out installation, maintenance and / or repair work, attention should be paid to the movable parts of the valve.

Maintenance and repair work

Before starting maintenance or repair work, the pneumatic or hydraulic cylinders and the piping system must be checked for residual energy (e.g. pressure buffer).

Automatic or remotely-operated valves must be disconnected from the automatic operation system or remote control system for the duration of the maintenance or repair work.

Pneumatic cylinders equipped with an opening or closing spring may only be disassembled at the factory of the manufacturer.

End valves

The user has the responsibility for taking care that all risks of accident are avoided by taking suitable precautions in the danger zone for valves used as inlet valves. (The legal stipulations are to be followed here.)

3.2 Removal of additional corrosion preventative

Before the final installation of the valves, any corrosion preventative that has been applied as per section 2.2 above must be thoroughly removed. All parts, and in particular the valve plate, spindle and piston rod, must be free of dust and dirt and, if necessary, well lubricated with a suitable lubricant before being used for the first time.

Recommended lubricants:

Shell Alvania R2, Molikote-Longtherm 2 Plus or equivalent.

3.3 Preservation of EKB (epoxy powder coating) and special painting

Damage to the protected surfaces arising during installation or transport must be repaired by an expert. Damage of this type is not covered by the warranty.

3.4 Protection of the Valve

If there is construction work still going on near or above the valves, they must be covered to protect them against this construction work.

When painting the installation, the spindle, electrical components and the plate projecting from the housing when the valve is open must not be painted. Any solvents used to remove unwanted paint must not come into contact with the seals under any circumstances. This applies especially to the area where the valve plate projects from the housing. If the installation is to be first cleaned by sand-blasting, the valves must be covered with special care.

Debris from sand-blasting, and especially sand-blasting grit, which gets into those parts of the installation that will be in contact with the valve during subsequent operation of the installation, must be removed carefully. Sand-blasting grit can destroy the valve plates and seals within a very short time.

3.5 Place of installation

The possible locations for installing the valve must be selected such that surfaces A and B are freely accessible for both sides to allow the seals to be readjusted if necessary.

Ensure that there is the necessary amount of space available for the packing tool C.

3.6 Position of installation

The position of installation of the respective valve must be chosen so that operation will be affected as little as possible by the medium.

Valves should normally be installed upright in horizontal pipelines, i.e., actuator on top, and horizontally in vertical pipelines. In the case of technically difficult installation conditions or in the case of custom-made valves, please contact the manufacturer if there is any doubt regarding the exact position of installation.

3.7 Direction of flow

The direction of flow must be according to the direction of the arrow in custom-made valves.

4. Mounting

4.1 Avoid under all circumstances any tension or stresses in the valve housing caused by piping that has not been aligned correctly or from piping that is under thermal stress.

4.2 Final remarks

Valves must always be installed near to supports in order to avoid stresses and tensions caused by bending elements.

4.3 Valves of the AT 200 series can be installed between flanges or as inlet / outlet valves. If valves of the AT 100 / AT 150 series are to be used as inlet / outlet valves, we recommend the use of an additional counterflange (e.g. as per DIN 2642).

5. Initial Operation

5.1 General measures

Before finally putting the valves into service, all the important elements (plate, spindle, piston rod, etc.) must be cleaned thoroughly. Any damage to the plate, especially to the seal as a result of sand-blasting debris or welding beads, external rust, etc., is not covered by the warranty.

Cleaning agents that include solvents especially those based on aromatic hydrocarbons (thinners, petroleum spirit and the like) must not be allowed to get into contact with the seal.

5.2 Shutting off powdery or granular media

When shutting off powdery or granular media, ensure that any wetness or humidity caused by the installation work and which might cause a subsequent caking of the medium must be thoroughly removed before the installation is started up when using the medium. Malfunctions of the valve caused by agglutination or caking of powdery media are not covered by the warranty.

5.3 Control pressure / use of control media

Check the input of the control pressure as the maximum permissible upper limit before applying pressure to hydraulic and pneumatic cylinders. The maximum permissible control pressure will be stated in the order confirmation. No other medium may be used other than the specified.

5.4 Pneumatically-operated valves

Before initial operation, all the air lines provided by the customer as well as the pneumatic control valves must be thoroughly blown and also cleaned if necessary.

We recommend the use of lightly oiled compressed air to actuate the cylinder. We recommend the following oils for the maintenance units: Shell Tellus Oil C 10, Wintershall Wiolan HN 46 or equivalent.

In operation, 1-2 drops per 1000 litres of air will be sufficient. Unless explicitly stated otherwise when ordering, pneumatic control valves installed by us are supplied without accessories such as chokes or silencers. The stipulations at the customer's site must be followed.

Pneumatically-operated valves should not be closed suddenly, as otherwise there is a risk of pressure shock (i.e. water-hammer).

5.5 Hydraulically-operated valves

Before initial operation, all the control lines provided by the customer must be thoroughly cleaned. We recommend the use of the following oils to actuate the cylinder: Wintershall Wiolan HN 46 or equivalent.

Hydraulically-operated valves should not be closed suddenly, as otherwise there is a risk of pressure shocks (i.e. water-hammer). Choker valves set at the factory must not be altered.

5.6 Electrically-operated valves of series AT 100 / 150 / 200 / 300 / 400 / 600

Closing may be done exclusively according to our instructions, as follows:

- only switch off in the closing direction by using a torque switch
- only switch off in the opening direction by using the path switch, the torque switch that is there serves as overload protection and must also be closed
- **in the case of custom-made valves such as of series AT 700 / 750, switching-off is done according to our separate instructions**

In the case of freely programmable controllers, the path switch and torque switch must be connected immediately before the contactor coils. For functional reasons, only self-locking actuators may be used.

Signal transfer at the path switch and torque switch to switch off the electrical actuator must be done in real time. Signal chaining via multiple contactors or positioning units causes the drive units to run on and can lead to the destruction of certain components.

To avoid any risk of damage to the valve before it is operated electrically for the first time, move the plate by hand to the middle position and only then operate the valve by means of the actuator.

Check the phase sequence when connecting the power supply. The path switch and torque switch cannot operate if the phase sequence is wrong.

The electrical actuator may not be operated unless the torque and limit switch function correctly. The torque set at the factory must **not** be changed. If it is necessary to do this in exceptional cases, only do so after consulting the manufacturer.

The heating and thermo-switches must be connected without fail to avoid a buildup of condensation and overheating of the motor. Follow the special operating instructions of the relevant actuator manufacturer.

5.7 Bitumen valves

The valves were tested under pressure at the factory using water at the test bench at normal room temperature. Before initial operation and in the heating-up phase at the bitumen-processing unit, the seals of all valves should be readjusted as per sections 6.1 and 6.2 below.

If, however, any leakages are found after filling the unit with bitumen, then the readjusting as per sections 6.1 and 6.2 below should be repeated. Bitumen leakages and cooled remnants must be removed carefully to prevent the seal from being destroyed in subsequent operation.

6. Recommendations for the maintenance of DOMINO valves

6.1 Readjusting the seal

During prolonged storage and in the event of larger temperature fluctuations, the sealing material of the seal of the narrow face may shrink or else release air trapped in the seal and thus can cause minor leakages on the narrow face of the plate.

If any leakage is found in the transverse seal in initial operation during the pressure test or after readjusting the seal (as per the instructions for installation of the block profile transverse seal) or after a prolonged period of disuse, and this still persists even after operating the valve several times, then the seal can easily be re-tensioned while the valve is still installed. The valve should not, however, be under full operating pressure when this work is done.

6.2 Minor leaks

Minor leaks can be eliminated by tightening the packing hole screws (A). If this does not produce any significant improvement, remove the packing hole screws (A) and apply the packing material (B) by means of the packing tool (C) until the valve is tight. In the case of valves sealed with a transverse seal, take care that the packing tool is pushed into the hole provided in the seal and the packing material is compressed between the seals.

The packing hole screws (A) should be tightened up again by about 3 turns.

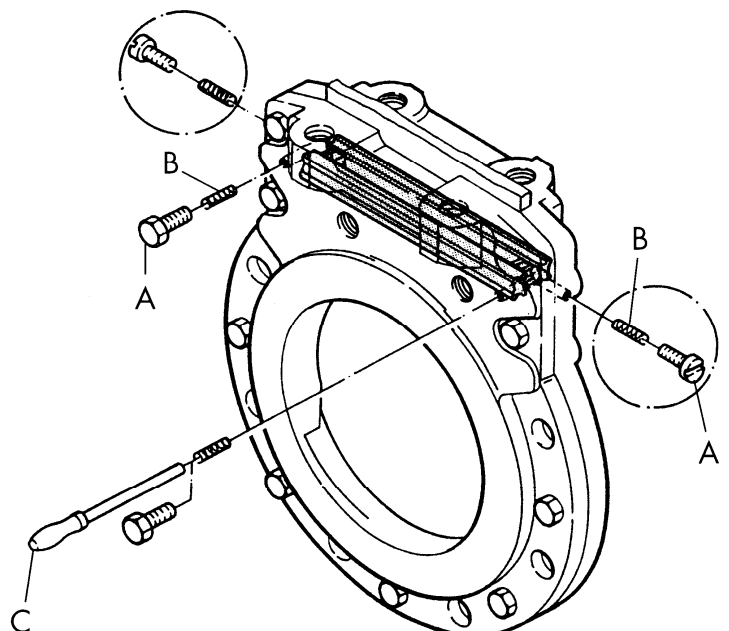

6.3 Lubrication of valves

Valves with hand-wheel operation

The spindle must always be kept well greased and free of dirt. The greasing points on the hand wheel bearing must be regreased regularly depending on the conditions of operation and use.

Valves with pneumatic or hydraulic operation

The piston rod should be clean and free of dirt. A self-lubricating rod seal is used as standard with pneumatic cylinders with damping. All the seals should be replaced if these cylinders leak.

Electrically-operated valves

The spindle must always be kept well greased and free of dirt. The greasing points on the actuator must be checked. The respective instructions for use of the actuator manufacturer are binding.

Recommended lubricants:

Shell Alvania R2, Molikote-Longtherm 2 Plus or equivalent.

6.4 Cleaning

If specified by the customer, the valves can be provided with flushing or blowing facilities in the upper part of the housing. Depending on the medium to be shut off and with regard to the process in question, the valve should be flushed or blown during opening and closing.

Depending on the application, the valve plate and plate guides must also be cleaned.

If the valve is seldom operated, and especially in the case of automatic valves, a test run should be made at least every 3 months to ensure permanent readiness for use and to avoid deposits from becoming baked on.

7. **Final remarks**

The details given here correspond to the latest state of our knowledge and, in connection with the technical documentation, the purpose of providing information about our products and their range of applications. They are not meant to guarantee particular features of the products or their suitability for specific applications.

Any existing copyrights and patent rights must be taken into consideration. We guarantee the quality within the scope of our terms and conditions of sale.

We reserve the right to make changes and improvements.