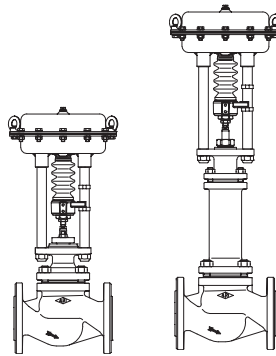


With pneumatic and electric actuators

**ARI-STEVI® 470 / 471**
**Pneumatic actuator  
ARI-DP 32 - 35**

- Reversible pneumatic actuator
- Actuator with rolling diaphragm
- Air supply pressure max. 6 bar
- Stem protection by bellow
- Maintenance-free O-ring sealing
- Assembly of additional devices acc. to DIN IEC 60534-6



Page 4

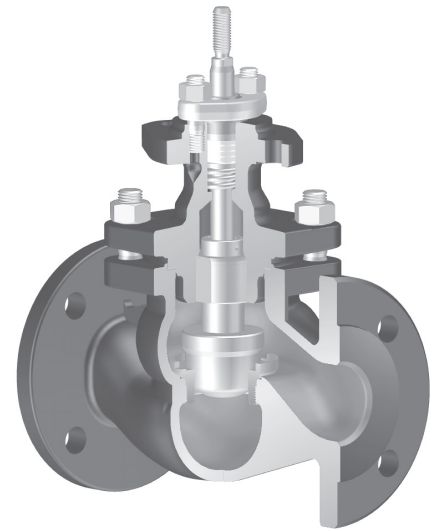
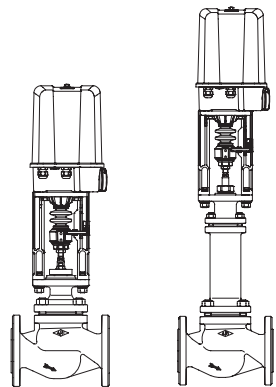


Fig. 470

**ARI-STEVI® 470 / 471**
**Electric actuator  
ARI-PREMIO 2,2 - 15 kN  
ARI-PREMIO-Plus 2G 2,2 - 15kN**

- Enclosure IP 65
- 2 torque switches
- Handwheel
- Additional devices available, e.g. potentiometer



Page 14

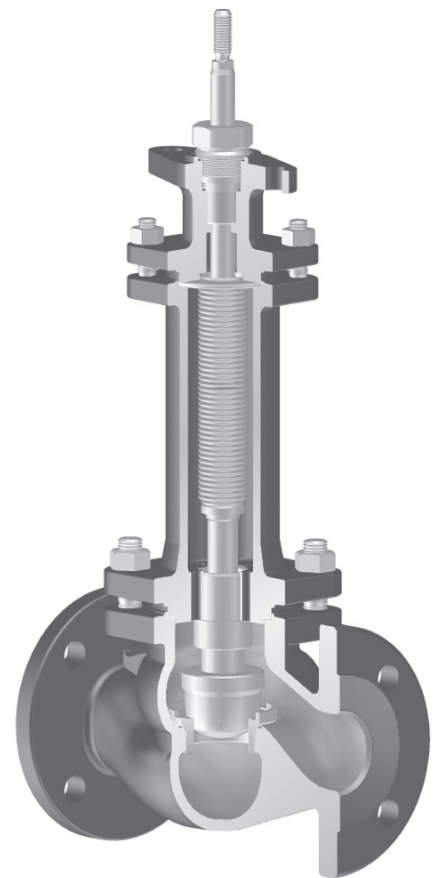
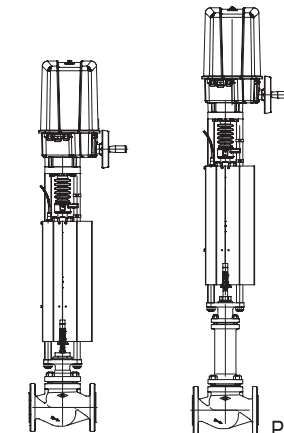


Fig. 471

**ARI-STEVI® 470 / 471**
**Electric actuator  
with fail-safe function  
ARI-PREMIO-Plus 2G 9 kN**

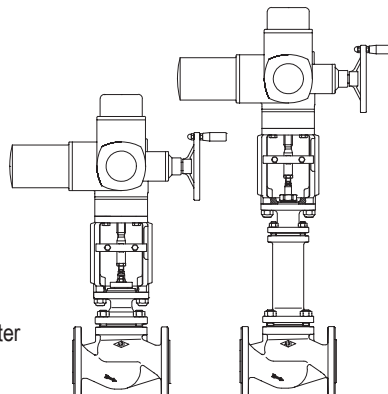
- Enclosure IP 65
- 2 torque switches
- Handwheel
- Additional devices available, e.g. potentiometer



Page 16

**ARI-STEVI® 470 / 471**
**Electric actuator  
AUMA SAR 07.2 - 14.6**

- Enclosure IP 67
- 2 torque switches
- 2 travel switches
- Handwheel
- Overheating protection for motor as standard
- Additional devices available, e.g. potentiometer
- Explosion proof version available



Page 18

Figure	Nominal pressure	Material	Nominal diameter	
12.470 / 12.471	PN16	EN-JL1040	DN15-150	Information / restriction of technical rules need to be observed! ARI-Valves of EN-JL1040 are not allowed to be operated in systems acc. to TRD 110.
22.470 / 22.471	PN16	EN-JS1049	DN15-150	
23.470 / 23.471	PN25	EN-JS1049	DN15-150	
34.470 / 34.471	PN25	1.0619+N	DN15-150	
35.470....4 / 35.471....4	PN40	1.0619+N	DN25-150	
54.470 ....1	PN25	1.4581	DN15-150	A production permission acc. to TRB 801 No. 45 is available. (Acc. to TRB 801 No. 45 EN-JL1040 is not allowed.)  The engineer, designing a system or a plant, is responsible for the selection of the correct valve.  Resistance and fitness must be verified, contact manufacturer for information (refer to Product overview and Resistance list).
55.470 ....1	PN40	1.4581	DN15-150	
Other materials and versions on request.				

Stem sealing			
Fig. 470	standard	optional	
	DN15- 150	DN15- 150	DN15- 150
	I. PTFE-V-ring unit -10°C to 220°C	I. EPDM-sealing -10°C to 150°C (allowed for water and steam up to 180°C)	II. PTFE-packing -10°C to 250°C II. Pure graphite-packing -10°C to 450°C

Fig. 471	standard	optional	
	DN15- 150	DN15- 100	DN125-150
	III. Stainless steel-bellow with pure graphite-packing -60°C to 450°C	III. Stainless steel-bellow with V-ring unit -60°C to 220°C	III. Stainless steel bellows seal with EPDM-sealing -60°C to 150°C (allowed for water and steam up to 180°C)

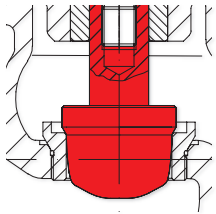
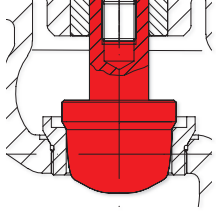
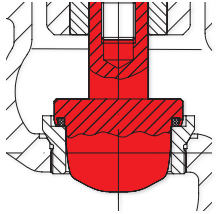
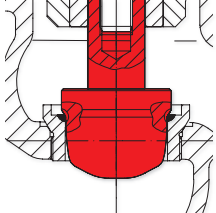
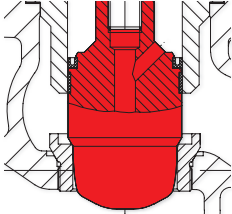
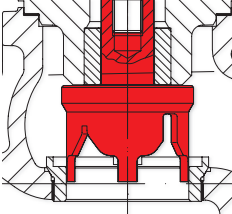


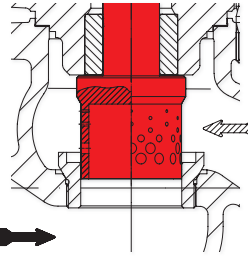

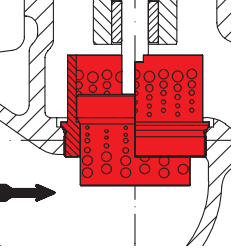
**Pressure-temperature-ratings** Intermediate values for max. permissible operational pressures can be determined by linear interpolation of the given temperature / pressure chart.

acc. to DIN EN 1092-2			-60°C to <-10°C <sup>1)</sup>	-10°C to 120°C	150°C	200°C	250°C	300°C	350°C	400°C	450°C
EN-JL1040	PN16	(bar)	--	16	14,4	12,8	11,2	9,6	--	--	--
EN-JS1049	PN16	(bar)	on request	16	15,5	14,7	13,9	12,8	11,2	--	--
EN-JS1049	PN25	(bar)	on request	25	24,3	23	21,8	20	17,5	--	--

acc. to manufacturers standard			-60°C to <-10°C <sup>1)</sup>	-10°C to 120°C	150°C	200°C	250°C	300°C	350°C	400°C	450°C
1.0619+N	PN25	(bar)	18,7	25	23,9	22	20	17,2	16	14,8	8,2
1.0619+N	PN40	(bar)	30	40	38,1	35	32	28	25,7	23,8	13,1

acc. to DIN EN 1092-1			-60°C to <-10°C <sup>1)</sup>	-10°C to 100°C	150°C	200°C	250°C	300°C	350°C	400°C	450°C
1.4581	25	(bar)	12,5	25	24,5	23,3	22,1	20,8	20,1	19,5	--
1.4581	40	(bar)	20	40	39,2	37,3	35,4	33,3	32,1	31,2	--

<sup>1)</sup> Valve with extended bonnet, studs and nuts made of A4-70 (at temperatures below -10°C)

Plug design standard		Guiding	Rangeability
<b>Parabolic plug, metal seat</b>	<ul style="list-style-type: none"> <li>- Leakage class IV acc. to DIN EN 60534-4</li> <li>- from Kvs 0,1</li> <li>- Flow characteristic: equal percentage (glp) (from Kvs 100 modified) linear (lin) (from Kvs 1)</li> </ul>	 Plug shaft	50 : 1
Plug design optional		Guiding	Rangeability
<b>Parabolic plug, tight closure</b>	<ul style="list-style-type: none"> <li>- Leakage class IV-S1 acc. to DIN EN 60534-4 (special actuator forces necessary)</li> <li>- from Kvs 0,1</li> <li>- Flow characteristic: equal percentage (glp) (from Kvs 100 modified) linear (lin) (from Kvs 1)</li> </ul>	 Plug shaft	50 : 1
<b>Parabolic plug with PTFE-soft seal (max. 200°C)</b>	<ul style="list-style-type: none"> <li>- Leakage class VI acc. to DIN EN 60534-4</li> <li>- from Kvs 1,0</li> <li>- Flow characteristic: equal percentage (glp) (from Kvs 100 modified) linear (lin)</li> </ul>	 Plug shaft	50 : 1
<b>Parabolic plug with armoured sealing edge</b>	<ul style="list-style-type: none"> <li>- Leakage class IV acc. to DIN EN 60534-4</li> <li>- from Kvs 1,0</li> <li>- Flow characteristic: equal percentage (glp) (from Kvs 100 modified) linear (lin)</li> </ul>	 Plug shaft	50 : 1
<b>Parabolic plug with pressure balanced plug metal seat</b> Piston seal: PTFE with stainless steel spring (max. 200°C)	<ul style="list-style-type: none"> <li>- Leakage class IV acc. to DIN EN 60534-4</li> <li>- from Kvs 6,3</li> <li>- Flow characteristic: equal percentage (glp) (from Kvs 100 modified) linear (lin)</li> </ul>	 Plug shaft	50 : 1
<b>V-port plug metal seat</b>	<ul style="list-style-type: none"> <li>- Leakage class IV acc. to DIN EN 60534-4</li> <li>- from Kvs 63</li> <li>- Flow characteristic: equal percentage (glp) (from Kvs 100 modified) linear (lin)</li> </ul>	 Plug shaft / Seat ring	30 : 1
<b>Perforated plug metal seat</b>  <b>optional: Pressure balanced perforated plug metal seat</b> Piston seal: PTFE with stainless steel spring (max. 200°C)	<ul style="list-style-type: none"> <li>- Leakage class IV acc. to DIN EN 60534-4</li> <li>- from Kvs 1</li> <li>- Flow characteristic: equal percentage (glp) (from Kvs 100 modified) linear (lin)</li> </ul> <p>  Flow direction for gas and steam to reduce the sound level   Flow direction for liquids at critical operating conditions (cavitation / flashing)         </p>	 Plug shaft / Seat ring	30 : 1
<b>Perforated plug with supporting basket metal seat</b>	<ul style="list-style-type: none"> <li>- Leakage class IV acc. to DIN EN 60534-4</li> <li>- from Kvs 1</li> <li>- Flow characteristic: equal percentage (glp) (from Kvs 100 modified) linear (lin)</li> <li>- multistage pressure reduction</li> </ul> <p>  Flow direction for gas / steam and liquids to reduce the sound level at critical operating conditions         </p>	 Plug shaft / Seat ring	30 : 1

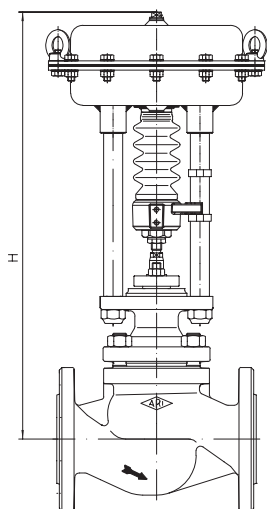
**Control valve in straightway form with pneumatic actuator ARI-DP**


Fig. 470

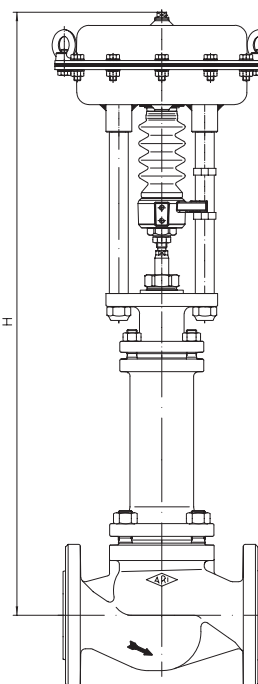
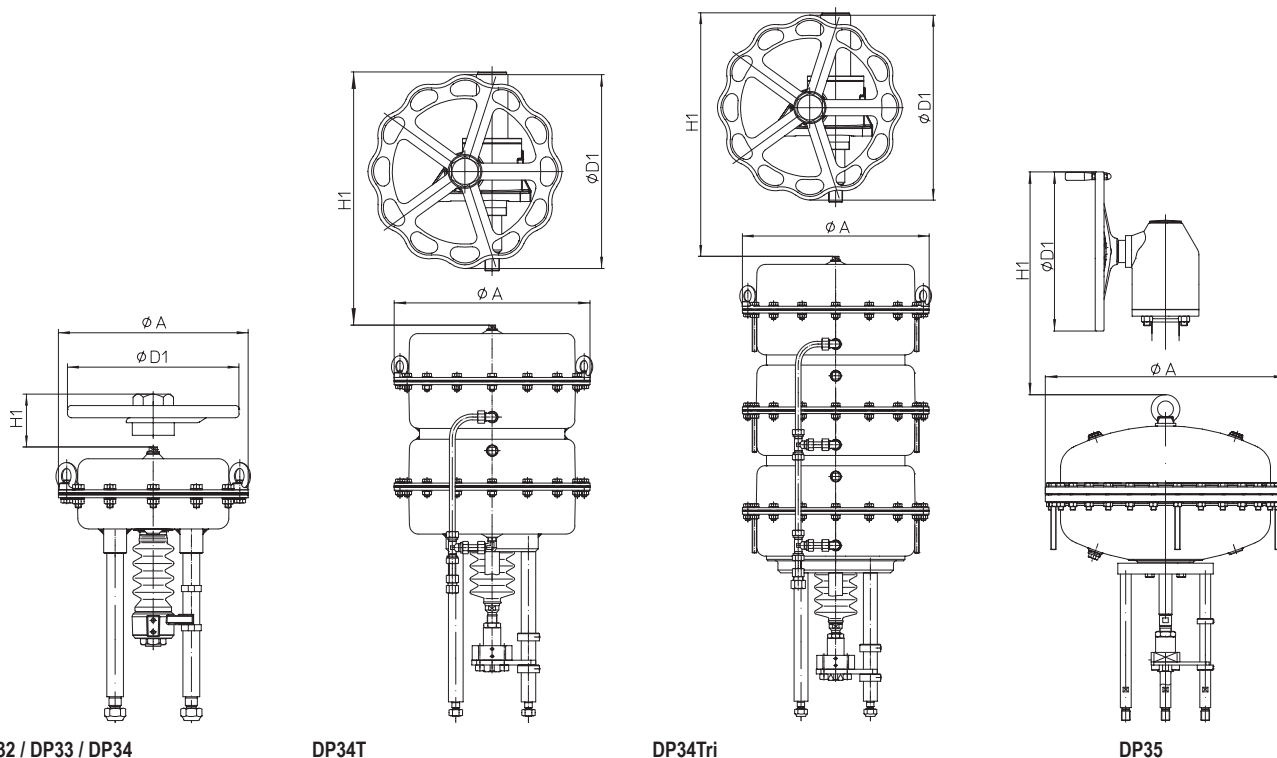


Fig. 471

**Heights and weights**

DN				15	20	25	32	40	50	65	80	100	125	150
Fig. 470	DP32	H	(mm)	470	470	473	473	504	504	489	522	524	579	584
		PN16 / 25	(kg)	16	17	18	19	24	26	30	40	54	75	99
		PN 40	(kg)	16	18	19	21	26	28	33	45	61	83	109
	DP33	H	(mm)	525	525	528	528	559	559	555	588	590	645	650
		PN16 / 25	(kg)	22	23	24	25	30	32	36	46	60	81	105
		PN 40	(kg)	22	24	25	27	32	34	39	51	67	89	115
	DP34	H	(mm)	--	--	--	--	694	694	690	723	725	780	785
		PN16 / 25	(kg)	--	--	--	--	60	62	66	76	90	111	135
		PN40	(kg)	--	--	--	--	62	64	69	81	97	119	145
	DP34T	H	(mm)	--	--	--	--	--	--	--	--	--	1021	1051
		PN16 / 25	(kg)	--	--	--	--	--	--	--	--	--	190	222
		PN40	(kg)	--	--	--	--	--	--	--	--	--	197	232
	DP34Tri	H	(mm)	--	--	--	--	--	--	--	--	--	1243	1273
		PN16 / 25	(kg)	--	--	--	--	--	--	--	--	--	224	256
		PN 40	(kg)	--	--	--	--	--	--	--	--	--	231	266
DP35	H	(mm)	--	--	--	--	--	--	--	--	--	1124	1154	
	PN16 / 25	(kg)	--	--	--	--	--	--	--	--	--	389	421	
	PN40	(kg)	--	--	--	--	--	--	--	--	--	396	431	
Fig. 471	DP32	H	(mm)	627	627	630	630	715	715	713	722	752	905	911
		PN16 / 25	(kg)	18	19	19	21	27	29	39	47	62	89	116
		PN 40	(kg)	19	20	20	22	28	30	41	50	66	99	123
	DP33	H	(mm)	682	682	685	685	770	770	779	788	818	971	977
		PN16 / 25	(kg)	24	25	25	27	33	35	45	53	68	95	122
		PN40	(kg)	25	26	26	28	34	36	47	56	72	105	129
	DP34	H	(mm)	--	--	--	--	905	905	914	923	953	1106	1112
		PN16 / 25	(kg)	--	--	--	--	63	65	75	83	98	125	152
		PN 40	(kg)	--	--	--	--	64	66	77	86	102	135	159
	DP34T	H	(mm)	--	--	--	--	--	--	--	--	--	1543	1573
		PN16 / 25	(kg)	--	--	--	--	--	--	--	--	--	223	254
		PN40	(kg)	--	--	--	--	--	--	--	--	--	230	265
	DP34Tri	H	(mm)	--	--	--	--	--	--	--	--	--	1765	1795
		PN16 / 25	(kg)	--	--	--	--	--	--	--	--	--	257	288
		PN 40	(kg)	--	--	--	--	--	--	--	--	--	264	299
DP35	H	(mm)	--	--	--	--	--	--	--	--	--	1613	1643	
	PN16 / 25	(kg)	--	--	--	--	--	--	--	--	--	422	453	
	PN40	(kg)	--	--	--	--	--	--	--	--	--	429	464	

Further dimensions refer to pages 20-23.



DP32 / DP33 / DP34

DP34T

DP34Tri

DP35

Actuator data		DP32	DP33	DP34	DP34T	DP34Tri	DP35
Ø A	(mm)	250	300	405		755	
Effective diaphragm area	(cm <sup>2</sup> )	250	400	800	1600	2400	2800
Top mounted handwheel	Ø D1 (mm)	225	300	400		500	
	H1 (mm)	270	284	442	635	635	731
	Weight (kg)	5		17	41		49

Further technical data of the actuator: refer to data sheet ARI-DP.

max. permissible closing pressures on flow-to-open P2 = 0.  
Observe pressure-temperature-limits, refer to page 2.

DN			15				20					25					32			40									
Parabolic plug	Kvs-value	(m³/h)	0,25/ 0,16/ 0,1	0,63/ 0,4	2,5/ 1,6/ 1	4	0,25/ 0,16/ 0,1	0,63/ 0,4	2,5/ 1,6/ 1	4	6,3	0,25/ 0,16/ 0,1	0,63/ 0,4	2,5/ 1,6/ 1	4	6,3	10	6,3	10	16	10	16	25						
	max. diff. pressure <sup>1)</sup>	(bar)	40				40					40					40			40			30						
Perforated plug	Kvs-value	(m³/h)	--			2,5/ 1,6/ 1	--				2,5	4	--			2,5	4	6,3	4	6,3	10	6,3	10	16					
	max. diff. pressure <sup>1)</sup>	(bar)	--			40	--				40		--			40			40			40							
Seat-Ø			(mm)	3	5	12	18	3	5	12	18	22	3	5	12	18	22	25	22	25	32	25	32	40					
Travel			(mm)	20				20					20					20			20			30					
	Spring range (bar)	Air supply pressure min. (bar) <sup>2)</sup>	0,2-1,0	1,2	I. (bar)	30,6	29,2	21,2	8,1	30,6	29,2	21,2	8,1	4,8	30,6	29,2	21,2	8,1	4,8	3,3	4,8	3,3	1,3	2,5					
					II. (bar)	20	18,6	11,9	3,8	20	18,6	11,9	3,8	1,8	20	18,6	11,9	3,8	1,8	1	1,8	1							
					III. (bar)	2,3	2	1		2,3	2	1																	
			0,4-1,2	1,4	I. (bar)	40			25,8	40			25,8	16,8	40			25,8	16,8	12,6	16,8	12,6	7,1	11,9	6,7	3,8			
					II. (bar)	40			21,4	40			21,4	13,8	40			21,4	13,8	10,3	13,8	10,3	5,7	8,8	4,8	2,6			
					III. (bar)	11,2	10,9	9,9	9	11,2	10,9	9,9	9	8,4	9,7	9,4	8,4	7,5	7	6,5	7	6,5	3,6	6,5	3,6	6,5	3,6	1,8	
	0,8-2,4	2,7	I. (bar)				40				40	40				40	40	31,4	40	31,4	18,7	30,6	18,3	11,3					
			II. (bar)				40				40	37,8				40	37,8	29,1	37,8	29,1	17,3	27,5	16,4	10,1					
			III. (bar)	28,9	28,6	27,6	26,7	28,9	28,6	27,6	26,7	26,2	27,5	27,2	26,2	25,3	24,7	24,3	24,7	24,3	15,2	24,3	15,2	9,3					
	1,5-2,9	3,2	I. (bar)															40		40	39	40	38,6						
			II. (bar)								40					40		40		40	37,6	40	36,7						
			III. (bar)	40			40			40			40			40			35,5			40			35,5				
2,0-3,8	4,1	I. (bar)																		40		40							
		II. (bar)																		40		40							
		III. (bar)																		40		40							

DN			50			65			80			100			125			150		
Parabolic plug	Kvs-value	(m³/h)	16	25	40	25	40	63	40	63	100	63	100	160	100	160	160			
	max. diff. pressure <sup>1)</sup>	(bar)	40	30		30			15	30	15	8	15	8	4	8	4	4		
V-port plug	Kvs-value	(m³/h)	--			--			63	--	63	100	63	100	160	100	160	160		
	max. diff. pressure <sup>1)</sup>	(bar)	--			--			30	--	30		30			25	30	25	25	
Perforated plug	Kvs-value	(m³/h)	10	16	25	16	25	40	25	40	63	40	63	100	63	100	100			
	max. diff. pressure <sup>1)</sup>	(bar)	40	40		40			40			40			40			40		
Seat-Ø			(mm)	32	40	50	40	50	65	50	65	80	65	80	100	80	100	100		
Travel			(mm)	20	30		30			30			30			30			30	
	Spring range (bar)	Air supply pressure min. (bar) <sup>2)</sup>	0,4-1,2	1,4	I. (bar)	6,7	3,8	2,1	3,8	2,1		2								
					II. (bar)	4,8	2,6	1,3	2,6	1,3		1,1								
					III. (bar)	3,6	1,8		1,8											
			0,8-2,4	2,7	I. (bar)	18,3	11,3	6,9	11,3	6,9	3,8	6,8	3,7	2,2	3,7	2,2	1,2	2,2	1,2	1,2
					II. (bar)	16,4	10,1	6,1	10,1	6,1	3,3	5,9	3,2	1,9	3,2	1,9	1	1,9	1	1
					III. (bar)	15,2	9,3	5,6	9,3	5,6	3	5,6	3	1,8	3	1,8		1,5		
	1,5-2,9	3,2	I. (bar)	38,6																
			II. (bar)	36,7																
			III. (bar)	35,5																
	2,0-3,8	4,1	I. (bar)	40																
			II. (bar)	40																
			III. (bar)	40																

I. Fig. 470: PTFE-V-ring unit / EPDM-sealing

II. Fig. 470: PTFE- / pure graphite-packing

III. Fig. 471: Bellows seal

<sup>1)</sup> max. differential pressure drop

<sup>2)</sup> Air supply pressure max. to actuator: 6 bar Restriction: a) 5 bar b) 4,5 bar c) 4 bar d) 3,5 bar e) 3 bar

max. permissible closing pressures on flow-to-open P2 = 0.  
Observe pressure-temperature-limits, refer to page 2.

DN			15				20					25					32			40					
Parabolic plug	Kvs-value	(m³/h)	0,25/ 0,16/ 0,1	0,63/ 0,4	2,5/ 1,6/ 1	4	0,25/ 0,16/ 0,1	0,63/ 0,4	2,5/ 1,6/ 1	4	6,3	0,25/ 0,16/ 0,1	0,63/ 0,4	2,5/ 1,6/ 1	4	6,3	10	6,3	10	16	10	16	25		
	max. diff. pressure <sup>1)</sup>	(bar)	40				40					40					40			40			30		
Perforated plug	Kvs-value	(m³/h)	--			2,5/ 1,6/ 1	--				2,5	4	--			2,5	4	6,3	4	6,3	10	6,3	10	16	
	max. diff. pressure <sup>1)</sup>	(bar)	---			40	---				40		---			40			40			40			
Seat-Ø		(mm)	3	5	12	18	3	5	12	18	22	3	5	12	18	22	25	22	25	32	25	32	40		
Travel		(mm)	20				20					20					20			20			30		
<b>DP32 250 cm<sup>2</sup></b> Spring opens on air failure  (stem retracting by spring)	Air supply pressure min. (bar) <sup>2)</sup>	1,4	I.	(bar)	40	25,8	40	25,8	16,8	40	40	40	25,8	16,8	12,6	16,8	12,6	7,1	11,9	6,7	3,8				
			II.	(bar)	40	21,4	40	21,4	13,8	40	40	40	21,4	13,8	10,3	13,8	10,3	5,7	8,8	4,8	2,6				
			III.	(bar)	11,2	10,9	9,9	9	11,2	10,9	9,8	9	8,4	9,7	9,4	8,4	7,5	7	6,5	7	6,5	3,6	6,5	3,6	1,8
		2	I.	(bar)	40				40					40					40	24,5	40	24,1	15,1		
			II.	(bar)	40				40					40					38,4	40	38,4	23,1	36,9	22,2	13,8
			III.	(bar)	37,8	37,5	36,5	35,6	37,8	37,5	36,5	35,6	35	36,3	36,1	35	34,2	33,6	33,2	33,6	33,2	21	33,2	21	13,1
	3	I.	(bar)	40				40					40					40			40	40	33,8		
		II.	(bar)	40				40					40					40			40	40	32,6		
		III.	(bar)	40				40					40					40			40	40	31,8		
	4	I.	(bar)	40				40					40					40			40	40	40		
		II.	(bar)	40				40					40					40			40	40	40		
		III.	(bar)	40				40					40					40			40	40	40		

DN			50			65			80			100			125			150	
Parabolic plug	Kvs-value	(m³/h)	16	25	40	25	40	63	40	63	100	63	100	160	100	160	160		
	max. diff. pressure <sup>1)</sup>	(bar)	40	30		30			15	30	15	8	15	8	4	8	4	4	
V-port plug	Kvs-value	(m³/h)	--			--			63	--	63	100	63	100	160	100	160	160	
	max. diff. pressure <sup>1)</sup>	(bar)	--			--			30	--	30		30			25	30	25	25
Perforated plug	Kvs-value	(m³/h)	10	16	25	16	25	40	25	40	63	40	63	100	63	100	100		
	max. diff. pressure <sup>1)</sup>	(bar)	40			40			40			40			40			40	
Seat-Ø		(mm)	32	40	50	40	50	65	50	65	80	65	80	100	80	100	100		
Travel		(mm)	20	30		30			30			30			30			30	
<b>DP32 250 cm<sup>2</sup></b> Spring opens on air failure  (stem retracting by spring)	Air supply pressure min. (bar) <sup>2)</sup>	1,4	I.	(bar)	6,7	3,8	2,1	3,8	2,1		2								
			II.	(bar)	4,8	2,6	1,3	2,6	1,3		1,1								
			III.	(bar)	3,6	1,8		1,8											
		2	I.	(bar)	24,1	15,1	9,3	15,1	9,3	5,2	9,2	5,1	3,2	5,1	3,2	1,8	3,2	1,8	1,8
			II.	(bar)	22,2	13,8	8,5	13,8	8,5	4,7	8,3	4,6	2,8	4,6	2,8	1,6	2,8	1,6	1,6
			III.	(bar)	21	13,1	8	13,1	8	4,4	8	4,4	2,7	4,4	2,7	1,5	2,4	1,4	1,4
		3	I.	(bar)	40	33,8	21,4	33,8	21,4	12,4	21,3	12,4	8	12,4	8	4,9	8	4,9	4,9
			II.	(bar)	40	32,6	20,6	32,6	20,6	11,9	20,4	11,8	7,6	11,8	7,6	4,7	7,6	4,7	4,7
			III.	(bar)	40	31,8	20,1	31,8	20,1	11,6	20,1	11,6	7,5	11,6	7,5	4,6	7,2	4,4	4,4
		4	I.	(bar)	40		33,5	40	33,5	19,6	33,4	19,6	12,7	19,6	12,7	8	12,7	8	8
			II.	(bar)	40		32,7	40	32,7	19,1	32,5	19	12,4	19	12,4	7,8	12,4	7,8	7,8
			III.	(bar)	40		32,2	40	32,2	18,9	32,2	18,9	12,3	18,9	12,3	7,7	12	7,5	7,5
		5	I.	(bar)	40			40	26,8	40	26,8	17,5	26,8	17,5	11,1	17,5	11,1	11,1	
			II.	(bar)	40			40	26,4	40	26,2	17,2	26,2	17,2	10,8	17,2	10,8	10,8	
			III.	(bar)	40			40	26,1	40	26,1	17	26,1	17	10,8	16,8	10,6	10,6	
		6	I.	(bar)					34		34	22,3	34	22,3	14,1	22,3	14,1	14,1	
			II.	(bar)					33,6		33,4	21,9	33,4	21,9	13,9	21,9	13,9	13,9	
			III.	(bar)					33,3		33,3	21,8	33,3	21,8	13,8	21,5	13,6	13,6	

- I. Fig. 470: PTFE-V-ring unit / EPDM-sealing
- II. Fig. 470: PTFE- / pure graphite-packing
- III. Fig. 471: Bellows seal

<sup>1)</sup> max. differential pressure drop

<sup>2)</sup> Air supply pressure max. to actuator: 6 bar      Restriction: a) 5 bar    b) 4,5 bar    c) 4 bar    d) 3,5 bar    e) 3 bar

max. permissible closing pressures on flow-to-open P2 = 0.  
Observe pressure-temperature-limits, refer to page 2.

DN			15				20				25				32			40								
Parabolic plug	Kvs-value	(m³/h)	0,25/ 0,16/ 0,1	0,63/ 0,4	2,5/ 1,6/ 1	4	0,25/ 0,16/ 0,1	0,63/ 0,4	2,5/ 1,6/ 1	4	6,3	0,25/ 0,16/ 0,1	0,63/ 0,4	2,5/ 1,6/ 1	4	6,3	10	6,3	10	16	10	16	25			
	max. diff. pressure <sup>1)</sup>	(bar)	40				40				40				40			40			30					
Perforated plug	Kvs-value	(m³/h)	--			2,5/ 1,6/ 1	--			2,5	4	--			2,5	4	6,3	4	6,3	10	6,3	10	16			
	max. diff. pressure <sup>1)</sup>	(bar)	--			40	--			40	--			40			40			40						
Seat-Ø		(mm)	3	5	12	18	3	5	12	18	22	3	5	12	18	22	25	22	25	32	25	32	40			
Travel		(mm)	20				20				20				20			20			30					
<b>DP33</b> <b>400 cm²</b> <b>Spring closes on air failure</b>  (stem extending by spring)	Spring range (bar)	Air supply pressure min. (bar) <sup>2)</sup>	0,2-1,0	1,2	I. (bar)	40c)	18,6c)	40c)	18,6c)	11,9c)	40c)	18,6c)	11,9c)	8,8c)	11,9c)	8,8c)	4,8c)	8a)	4,3a)	2,3a)						
				II. (bar)	40c)	34,4c)	14,2c)	40c)	34,4c)	14,2c)	8,9c)	40c)	34,4c)	14,2c)	8,9c)	6,5c)	8,9c)	6,5c)	3,4c)	5a)	2,4a)	1,1a)				
				III. (bar)	7,5a)	7,2a)	6,2a)	5,4a)	7,5a)	7,2a)	6,2a)	5,4a)	4,8a)	6,1a)	5,8a)	4,8a)	3,9a)	3,3a)	2,9a)	3,3a)	2,9a)	1,2a)	2,9a)	1,2a)		
			0,4-1,2	1,4	I. (bar)	40c)				40c)				31c)	40c)			31c)	23,7c)	31c)	23,7c)	14c)	22,9a)	13,5a)	8,3a)	
				II. (bar)	40c)				40c)				28c)	40c)			28c)	21,4c)	28c)	21,4c)	12,6c)	19,9a)	11,6a)	7a)		
				III. (bar)	21,7a)	21,4a)	20,4a)	19,5a)	21,7a)	21,4a)	20,4a)	19,5a)	18,9a)	20,2a)	19,9a)	18,9a)	18a)	17,5a)	17a)	17,5a)	17a)	10,5a)	17a)	10,5a)	6,3a)	
			0,8-2,4	2,7	I. (bar)									40a)	40a)			40a)	32,5a)	40	32	20,2				
				II. (bar)									40a)	40a)			40a)	31,1a)	40	30,1	19					
				III. (bar)	40				40				40			40	28,9	40	28,9	18,2						
			1,5-3,0	3,3	I. (bar)																					40
				II. (bar)																						39,9
				III. (bar)																						39,1
1,7-2,7	3,1	I. (bar)																40a)	40							
	II. (bar)																40a)	40								
	III. (bar)																40	40								
2,0-4,0	4,5	I. (bar)																						40		
	II. (bar)																							40		
	III. (bar)																							40		

DN			50			65			80			100			125		150			
Parabolic plug	Kvs-value	(m³/h)	16	25	40	25	40	63	40	63	100	63	100	160	100	160	160			
	max. diff. pressure <sup>1)</sup>	(bar)	40	30		30	15	30	15	8	15	8	4	8	4	4				
V-port plug	Kvs-value	(m³/h)	--			--	63	--	63	100	63	100	160	100	160	160				
	max. diff. pressure <sup>1)</sup>	(bar)	--			---	30	--	30			30			25	30	25	25		
Perforated plug	Kvs-value	(m³/h)	10	16	25	16	25	40	25	40	63	40	63	100	63	100	100			
	max. diff. pressure <sup>1)</sup>	(bar)	40	40		40			40			40			40		40			
Seat-Ø		(mm)	32	40	50	40	50	65	50	65	80	65	80	100	80	100	100			
Travel		(mm)	20	30		30			30			30			30		30			
<b>DP33</b> <b>400 cm²</b> <b>Spring closes on air failure</b>  (stem extending by spring)	Spring range (bar)	Air supply pressure min. (bar) <sup>2)</sup>	0,2-1,0	1,2	I. (bar)	4,3a)	2,3a)	1,1a)	2,3a)	1,1a)	1									
				II. (bar)	2,4a)	1,1a)	1,1a)													
				III. (bar)	1,2a)															
			0,4-1,2	1,4	I. (bar)	13,5a)	8,3a)	4,9a)	8,3a)	4,9a)	2,6a)	4,8	2,5	1,4	2,5	1,4	1,4			
				II. (bar)	11,6a)	7a)	4,1a)	7a)	4,1a)	2,1a)	3,9	2	1,1	2	1,1		1,1			
				III. (bar)	10,5a)	6,3a)	3,7a)	6,3a)	3,7a)	1,8a)	3,7	1,8	1	1,8	1					
			0,8-2,4	2,7	I. (bar)	32	20,2	12,6	20,2	12,6	7,2	12,5	7,1	4,5	7,1	4,5	2,7	4,5	2,7	2,7
				II. (bar)	30,1	19	11,8	19	11,8	6,7	11,6	6,6	4,1	6,6	4,1	2,5	4,1	2,5	2,5	
				III. (bar)	28,9	18,2	11,3	18,2	11,3	6,4	11,3	6,4	4	6,4	4	2,4	3,7	2,2	2,2	
			1,5-3,0	3,3	I. (bar)	40		26,1	40	26,1	15,2	26	15,1	9,8	15,1	9,8	6,1	9,8	6,1	6,1
				II. (bar)	39,9		25,3	39,9	25,3	14,7	25,1	14,6	9,5	14,6	9,5	5,9	9,5	5,9	5,9	
				III. (bar)	39,1		24,8	39,1	24,8	14,4	24,8	14,4	9,3	14,4	9,3	5,8	9	5,6	5,6	
1,7-2,7	3,1	I. (bar)	40																	
	II. (bar)	40																		
	III. (bar)	40																		
2,0-4,0	4,5	I. (bar)	35,7			35,7	20,9	35,6	20,9	13,6	20,9	13,6	8,5	13,6	8,5	8,5				
	II. (bar)	40		34,9	40	34,9	20,5	34,7	20,4	13,3	20,4	13,3	8,3	13,3	8,3	8,3				
	III. (bar)	40		34,4	40	34,4	20,2	34,4	20,2	13,1	20,2	13,1	8,2	12,9	8,1	8,1				


- I. Fig. 470: PTFE-V-ring unit / EPDM-sealing
- II. Fig. 470: PTFE- / pure graphite-packing
- III. Fig. 471: Bellows seal


<sup>1)</sup> max. differential pressure drop

<sup>2)</sup> Air supply pressure max. to actuator: 6 bar      Restriction: a) 5 bar    b) 4,5 bar    c) 4 bar    d) 3,5 bar    e) 3 bar



max. permissible closing pressures on flow-to-open P2 = 0.  
 Observe pressure-temperature-limits, refer to page 2.

DN			15				20					25					32			40						
Parabolic plug	Kvs-value	(m³/h)	0,25/ 0,16/ 0,1	0,63/ 0,4	2,5/ 1,6/ 1	4	0,25/ 0,16/ 0,1	0,63/ 0,4	2,5/ 1,6/ 1	4	6,3	0,25/ 0,16/ 0,1	0,63/ 0,4	2,5/ 1,6/ 1	4	6,3	10	6,3	10	16	10	16	25			
	max. diff. pressure <sup>1)</sup>	(bar)	40				40					40					40			40			30			
Perforated plug	Kvs-value	(m³/h)	--				2,5					4					6,3			10			16			
	max. diff. pressure <sup>1)</sup>	(bar)	--				40					--					40			40			40			
Seat-Ø		(mm)	3	5	12	18	3	5	12	18	22	3	5	12	18	22	25	22	25	32	25	32	40			
Travel		(mm)	20				20					20					20			20			30			
<b>DP33</b> <b>400 cm²</b> <b>Spring opens</b> <b>on air failure</b>  (stem retracting by spring)	Air supply pressure min. (bar) <sup>2)</sup>	1,4	I.	(bar)	40d)				40d)					31d)	40d)	40d)	40d)	31d)	23,7d)	31d)	23,7d)	14d)	22,9d)	13,5d)	8,3d)	
			II.	(bar)	40d)				40d)					28,2d)	40d)	40d)	40d)	28d)	21,4d)	28d)	21,4d)	12,6d)	19,9d)	11,6d)	7d)	
			III.	(bar)	21,7d)	21,4d)	20,4d)	19,5d)	21,7d)	21,4d)	20,4d)	19,5d)	18,9d)	20,2d)	19,9d)	18,9d)	18,2d)	17,5d)	17d)	17,5d)	17d)	10,5d)	17d)	10,5d)	6,3d)	
		2	I.	(bar)										40d)						40d)				40d)	26,2d)	
			II.	(bar)										40d)						40d)				40d)	39,3d)	24,9d)
			III.	(bar)	40d)				40d)					40d)					40d)	38,2d)	40d)	38,2d)	24,2d)			
		3	I.	(bar)																		40d)				
			II.	(bar)																		40d)				
			III.	(bar)															40d)				40d)			

DN			50			65			80			100			125			150		
Parabolic plug	Kvs-value	(m³/h)	16	25	40	25	40	63	40	63	100	63	100	160	100	160	160			
	max. diff. pressure <sup>1)</sup>	(bar)	40	30		30			15	30	15	8	15	8	4	8	4	4		
V-port plug	Kvs-value	(m³/h)	--			--			63	--	63	100	63	100	160	100	160	160		
	max. diff. pressure <sup>1)</sup>	(bar)	--			--			30	--	30		30			25	30	25	25	
Perforated plug	Kvs-value	(m³/h)	10	16	25	16	25	40	25	40	63	40	63	100	63	100	100			
	max. diff. pressure <sup>1)</sup>	(bar)	40	40		40			40			40			40					
Seat-Ø		(mm)	32	40	50	40	50	65	50	65	80	65	80	100	80	100	100			
Travel		(mm)	20	30		30			30			30			30					
<b>DP33</b> <b>400 cm²</b> <b>Spring opens</b> <b>on air failure</b>  (stem retracting by spring)	Air supply pressure min. (bar) <sup>2)</sup>	1,4	I.	(bar)	13,5d)	8,3d)	4,9d)	8,3d)	4,9d)	2,6d)	4,8d)	2,5d)	1,4d)	2,5d)	1,4d)	1,4d)				
			II.	(bar)	11,6d)	7d)	4,1d)	7d)	4,1d)	2,1d)	3,9d)	2d)	1,1d)	2d)	1,1d)	1,1d)				
			III.	(bar)	10,5d)	6,3d)	3,7d)	6,3d)	3,7d)	1,8d)	3,7d)	1,8d)	1d)	1,8d)	1d)					
		2	I.	(bar)	40d)	26,2d)	16,5d)	26,2d)	16,5d)	9,5d)	16,4d)	9,4d)	6d)	9,4d)	6d)	3,7d)	6d)	3,7d)	3,7d)	
			II.	(bar)	39,3d)	24,9d)	15,7d)	24,9d)	15,7d)	9d)	15,5d)	8,9d)	5,7d)	8,9d)	5,7d)	3,4d)	5,7d)	3,4d)	3,4d)	
			III.	(bar)	38,2d)	24,2d)	15,2d)	24,2d)	15,2d)	8,7d)	15,2d)	8,7d)	5,5d)	8,7d)	5,5d)	3,4d)	5,2d)	3,2d)	3,2d)	
		3	I.	(bar)		40d)	35,7d)	40d)	35,7d)	20,9d)	35,6d)	20,9d)	13,6d)	20,9d)	13,6d)	8,5d)	13,6d)	8,5d)	8,5d)	
			II.	(bar)	40d)		34,9d)	40d)	34,9d)	20,5d)	34,7d)	20,4d)	13,3d)	20,4d)	13,3d)	8,3d)	13,3d)	8,3d)	8,3d)	
			III.	(bar)	40d)		34,4d)	40d)	34,4d)	20,2d)	34,4d)	20,2d)	13,1d)	20,2d)	13,1d)	8,2d)	12,9d)	8,1d)	8,1d)	
		4	I.	(bar)			40a)		40a)	32,4a)	40	32,4	21,2	32,4	21,2	13,4	21,2	13,4	13,4	
			II.	(bar)			40a)		40a)	31,9a)	40	31,8	20,9	31,8	20,9	13,2	20,9	13,2	13,2	
			III.	(bar)			40a)		40a)	31,6a)	40	31,6	20,7	31,6	20,7	13,1	20,5	12,9	12,9	
		5	I.	(bar)						40a)		40	28,8	40	28,8	18,3	28,8	18,3	18,3	
			II.	(bar)						40a)		40	28,5	40	28,5	18,1	28,5	18,1	18,1	
			III.	(bar)						40a)		40	28,4	40	28,4	18	28,1	17,8	17,8	
		6	I.	(bar)									36,4		36,4	23,2	36,4	23,2	23,2	
			II.	(bar)									36,1		36,1	23	36,1	23	23	
			III.	(bar)									36		36	22,9	35,7	22,7	22,7	

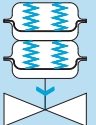
- I. Fig. 470: PTFE-V-ring unit / EPDM-sealing
- II. Fig. 470: PTFE- / pure graphite-packing
- III. Fig. 471: Bellows seal

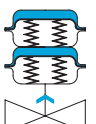
<sup>1)</sup> max. differential pressure drop

<sup>2)</sup> Air supply pressure max. to actuator: 6 bar      Restriction: a) 5 bar    b) 4,5 bar    c) 4 bar    d) 3,5 bar    e) 3 bar



max. permissible closing pressures on flow-to-open P2 = 0.  
Observe pressure-temperature-limits, refer to page 2.

DN				125			150				
Parabolic plug	Kvs-value		(m³/h)	100	160	250	160	250	400		
	max. diff. pressure <sup>1)</sup>		(bar)	8	4	2	4	2			
V-port plug	Kvs-value		(m³/h)	100	160	250	160	250	400		
	max. diff. pressure <sup>1)</sup>		(bar)	30	25	15	25	15			
Perforated plug	Kvs-value		(m³/h)	63	100	160	100	160	250		
	max. diff. pressure <sup>1)</sup>		(bar)	40			40				
Seat-Ø			(mm)	80	100	125	100	125	150		
Travel			(mm)	30		50	30	50			
<b>DP34T</b> <b>1600 cm²</b> Spring closes on air failure  (stem extending by spring)	Spring range (bar)	0,2-1,0	1,5	I.	(bar)	4,5	2,7	1,6	2,7	1,6	1
				II.	(bar)	3,7	2,2	1,2	2,2	1,2	
				III.	(bar)	3,5 a)	2 a)	1,1 a)	2 a)	1,1 a)	
		0,4-1,2	1,7	I.	(bar)	10,6	6,6	4,1	6,6	4,1	2,7
				II.	(bar)	9,8	6,1	3,8	6,1	3,8	2,5
				III.	(bar)	9,6 a)	6 a)	3,7 a)	6 a)	3,7 a)	2,4 a)
	0,8-2,4	2,9	I.	(bar)	22,9	14,5	9,2	14,5	9,1	6,3	
			II.	(bar)	22,1	14	8,8	14	8,8	6	
			III.	(bar)	21,8	13,8	8,7	13,8	8,7	6	
	1,5-3,0	3,5	I.	(bar)			18		18	12,4	
			II.	(bar)			17,7		17,7	12,2	
			III.	(bar)			17,6		17,6	12,1	
	2,1-3,0	3,5	I.	(bar)	40	40		40			
			II.	(bar)	40	39,6		39,6			
			III.	(bar)	40	39,4		39,4			
	2,0-4,0	4,5	I.	(bar)			24,3		24,3	16,8	
			II.	(bar)			24		24	16,6	
			III.	(bar)			23,9		23,9	16,5	
	2,4-3,6	4,1	I.	(bar)							
			II.	(bar)		40		40			
			III.	(bar)		40		40			

DN				125			150				
Parabolic plug	Kvs-value		(m³/h)	100	160	250	160	250	400		
	max. diff. pressure <sup>1)</sup>		(bar)	8	4	2	4	2			
V-port plug	Kvs-value		(m³/h)	100	160	250	160	250	400		
	max. diff. pressure <sup>1)</sup>		(bar)	30	25	15	25	15			
Perforated plug	Kvs-value		(m³/h)	63	100	160	100	160	250		
	max. diff. pressure <sup>1)</sup>		(bar)	40			40				
Seat-Ø			(mm)	80	100	125	100	125	150		
Travel			(mm)	30		50	30	50			
<b>DP34T</b> <b>1600 cm²</b> Spring opens on air failure  (stem retracting by spring)	Air supply pressure min. (bar) <sup>2)</sup>	1,5		I.	(bar)	13,7	8,6	5,3	8,6	5,3	3,6
				II.	(bar)	12,9	8,1	5	8,1	5	3,4
				III.	(bar)	12,6 a)	7,9 a)	4,9 a)	7,9 a)	4,9 a)	3,3 a)
		2		I.	(bar)	29	18,4	11,7	18,4	11,7	8
				II.	(bar)	28,2	17,9	11,3	17,9	11,3	7,8
				III.	(bar)	27,9 a)	17,8 a)	11,2 a)	17,8 a)	11,2 a)	7,7 a)
	3		I.	(bar)	40	38,1	24,3	38,1	24,3	16,8	
			II.	(bar)	40	37,6	24	37,6	24	16,6	
			III.	(bar)	40 a)	37,4 a)	23,9 a)	37,4 a)	23,9 a)	16,5 a)	
	4		I.	(bar)		40	36,9	40	36,9	25,6	
			II.	(bar)		40	36,6	40	36,6	25,4	
			III.	(bar)		40 a)	36,5 a)	40 a)	36,5 a)	25,3 a)	
	5		I.	(bar)			40		40	34,4	
			II.	(bar)			40		40	34,2	
			III.	(bar)			40 a)		40 a)	34,1 a)	
	6		I.	(bar)						40	
			II.	(bar)						40	

I. Fig. 470: EPDM-sealing

II. Fig. 470: PTFE- / pure graphite-packing

III. Fig. 471: Bellows seal

<sup>1)</sup> max. differential pressure drop

<sup>2)</sup> Air supply pressure max. to actuator: 6 bar      Restriction: a) 5 bar    b) 4,5 bar    c) 4 bar    d) 3,5 bar    e) 3 bar

max. permissible closing pressures on flow-to-open P2 = 0.  
Observe pressure-temperature-limits, refer to page 2.


DN				125			150				
Parabolic plug	Kvs-value	(m <sup>3</sup> /h)		100	160	250	160	250	400		
	max. diff. pressure <sup>1)</sup>	(bar)		8	4	2	4	2			
V-port plug	Kvs-value	(m <sup>3</sup> /h)		100	160	250	160	250	400		
	max. diff. pressure <sup>1)</sup>	(bar)		30	25	15	25	15			
Perforated plug	Kvs-value	(m <sup>3</sup> /h)		63	100	160	100	160	250		
	max. diff. pressure <sup>1)</sup>	(bar)		40			40				
Seat-Ø			(mm)	80	100	125	100	125	150		
Travel			(mm)	30		50	30	50			
<p>DP34Tri 2400 cm<sup>2</sup> Spring closes on air failure</p> <p>(stem extending by spring)</p>	Spring range (bar)	Air supply pressure min. (bar) <sup>2)</sup>	1,5	I. (bar)	7,5 a)	4,6 a)	2,8 a)	4,6 a)	2,8 a)	1,9 a)	
				II. (bar)	6,8 a)	4,1 a)	2,5 a)	4,1 a)	2,5 a)	1,6 a)	
				III. (bar)	6,5 d)	4 d)	2,4 d)	4 d)	2,4 d)	1,6 d)	
			0,4-1,2	1,7	I. (bar)	16,7 a)	10,6 a)	6,6 a)	10,6 a)	6,6 a)	4,5 a)
					II. (bar)	16 a)	10,1 a)	6,3 a)	10,1 a)	6,3 a)	4,3 a)
					III. (bar)	15,7 c)	9,9 c)	6,2 c)	9,9 c)	6,2 c)	4,2 c)
	0,8-2,4	2,9	I. (bar)	35,1	22,4	14,2	22,4	14,2	9,8		
			II. (bar)	34,3	21,9	13,9	21,9	13,9	9,5		
			III. (bar)	34,1 a)	21,7 a)	13,8 a)	21,7 a)	13,8 a)	9,5 a)		
	1,5-3,0	3,5	I. (bar)			27,5		27,5	19		
			II. (bar)			27,1		27,1	18,8		
			III. (bar)			27 a)		27 a)	18,7 a)		
	2,1-3,0	3,5	I. (bar)	40	40		40				
			II. (bar)	40	40		40				
			III. (bar)	40 a)	40 a)		40 a)				
	2,0-4,0	4,5	I. (bar)			36,9		36,9	25,6		
			II. (bar)			36,6		36,6	25,4		
			III. (bar)			36,5		36,5	25,3		


- I. Fig. 470: EPDM-sealing  
 II. Fig. 470: PTFE- / pure graphite-packing  
 III. Fig. 471: Bellows seal

<sup>1)</sup> max. differential pressure drop

<sup>2)</sup> Air supply pressure max. to actuator: 6 bar      Restriction: a) 5 bar    b) 4,5 bar    c) 4 bar    d) 3,5 bar    e) 3 bar

max. permissible closing pressures on flow-to-open P2 = 0.  
Observe pressure-temperature-limits, refer to page 2.

DN						125	150		
Parabolic plug	Kvs-value			(m <sup>3</sup> /h)		250	250	400	
	max. diff. pressure <sup>1)</sup>			(bar)		2	2		
V-port plug	Kvs-value			(m <sup>3</sup> /h)		250	250	400	
	max. diff. pressure <sup>1)</sup>			(bar)		15	15		
Perforated plug	Kvs-value			(m <sup>3</sup> /h)		160	160	250	
	max. diff. pressure <sup>1)</sup>			(bar)		40	40		
Seat-Ø					(mm)	125	125	150	
Travel					(mm)	50	50		
<b>DP35</b> <b>2800 cm<sup>2</sup></b> <b>Spring closes</b> <b>on air failure</b>  (stem extending by spring)	Spring range (bar)	2,45-3,28	Air supply pressure min. (bar) <sup>2)</sup>	3,8	I./II.	(bar)	40	40	37,4
					III.	(bar)	40 a)	40 a)	37,3 a)
		2,97-3,8	4,3	I./II.	(bar)			40	

DN						125	150				
Parabolic plug	Kvs-value			(m <sup>3</sup> /h)		250	250	400			
	max. diff. pressure <sup>1)</sup>			(bar)		2	2				
V-port plug	Kvs-value			(m <sup>3</sup> /h)		250	250	400			
	max. diff. pressure <sup>1)</sup>			(bar)		15	15				
Perforated plug	Kvs-value			(m <sup>3</sup> /h)		160	160	250			
	max. diff. pressure <sup>1)</sup>			(bar)		40	40				
Seat-Ø					(mm)	125	125	150			
Travel					(mm)	50	50				
<b>DP35</b> <b>2800 cm<sup>2</sup></b> <b>Spring opens</b> <b>on air failure</b>  (stem retracting by spring)	Air supply pressure min. (bar) <sup>2)</sup>	1,5			I./II.	(bar)	12,7 b)	12,7 b)	8,7 b)		
					III.	(bar)	12,6 e)	12,6 e)	8,6 e)		
		2					I./II.	(bar)	23,9 b)	23,9 b)	16,6 b)
							III.	(bar)	23,8 e)	23,8 e)	16,5 e)
		3					I./II.	(bar)	40 b)	40 b)	32,2 b)
							III.	(bar)	40 e)	40 e)	32,2 e)
		4					I./II.	(bar)			40 b)

I. Fig. 470: EPDM-sealing

II. Fig. 470: PTFE- / pure graphite-packing

III. Fig. 471: Bellows seal

<sup>1)</sup> max. differential pressure drop

<sup>2)</sup> Air supply pressure max. to actuator: 6 bar Restriction: a) 5 bar b) 4,5 bar c) 4 bar d) 3,5 bar e) 3 bar

## Control valve in straightway form with electric actuator ARI-PREMIO / PREMIO-Plus 2G

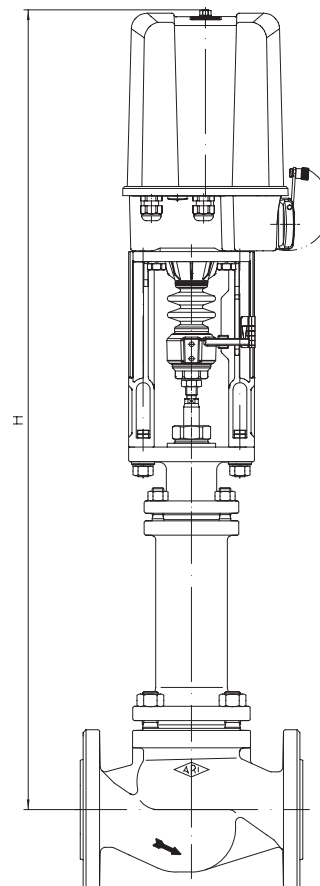
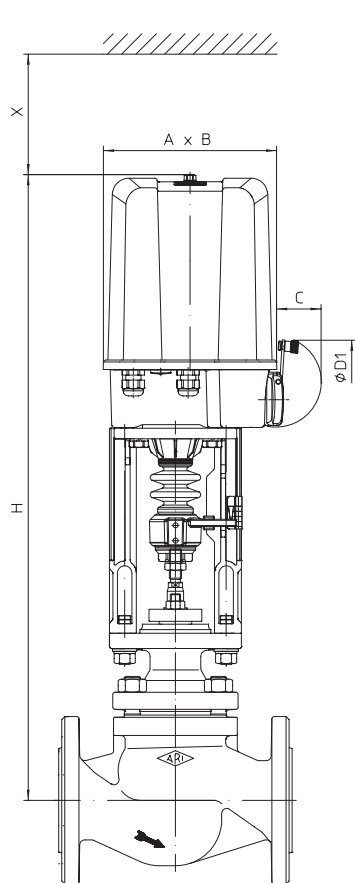


Fig. 470

Fig. 471

Actuator data		2,2 - 5 kN	12 - 15 kN
A	(mm)	171	202
B	(mm)	156	176
C	(mm)	50	97
Ø D1	(mm)	90	130
X	(mm)	150	200

**Motor voltage:** 230V 50Hz  
**Other voltages:** 24V 50/60Hz; 115V 50/60Hz; 230V 60Hz  
**Further technical data of the actuator:** refer to data sheet ARI-PREMIO/PREMIO-Plus 2G

## Heights and weights

DN		15	20	25	32	40	50	65	80	100	125	150		
Fig. 470	2,2 kN	H	(mm)	578	578	581	581	612	612	608	641	643	731	736
		PN16 / 25	(kg)	13	13	14	15	20	22	26	36	50	71	95
		PN40	(kg)	13	14	15	17	22	24	29	41	57	79	105
	5 kN	H	(mm)	578	578	581	581	612	612	608	641	643	731	736
		PN16 / 25	(kg)	13	14	15	17	21	23	28	38	52	73	97
		PN40	(kg)	14	15	16	18	23	25	31	42	58	81	107
	12 kN	H	(mm)	--	--	--	--	787	787	783	816	818	873	878
		PN16 / 25	(kg)	--	--	--	--	25	27	32	42	56	77	101
	15 kN	PN40	(kg)	--	--	--	--	27	29	35	46	62	85	111
Fig. 471	2,2 kN	H	(mm)	735	735	738	738	823	823	832	841	871	1057	1063
		PN16 / 25	(kg)	14	15	16	17	23	26	35	43	58	85	112
		PN40	(kg)	15	16	17	18	24	27	37	46	62	95	119
	5 kN	H	(mm)	735	735	738	738	823	823	832	841	871	1057	1063
		PN16 / 25	(kg)	15	16	17	18	25	27	36	44	60	87	114
		PN40	(kg)	16	17	18	20	25	28	38	47	63	97	121
	12 kN	H	(mm)	--	--	--	--	998	998	1007	1016	1046	1199	1205
		PN16 / 25	(kg)	--	--	--	--	29	31	40	48	64	91	118
	15 kN	PN40	(kg)	--	--	--	--	29	32	42	51	67	101	125

Further dimensions refer to pages 20-23.

max. permissible closing pressures on flow-to-open P2 = 0.  
Observe pressure-temperature-limits, refer to page 2.

DN			15				20					25					32			40																							
Parabolic plug	Kvs-value	(m³/h)	0,25/ 0,16/ 0,1	0,63/ 0,4	2,5/ 1,6/ 1	4	0,25/ 0,16/ 0,1	0,63/ 0,4	2,5/ 1,6/ 1	4	6,3	0,25/ 0,16/ 0,1	0,63/ 0,4	2,5/ 1,6/ 1	4	6,3	10	6,3	10	16	10	16	25																				
	max. diff. pressure <sup>1)</sup>	(bar)	40				40					40					40			40			30																				
Perforated plug	Kvs-value	(m³/h)	--				2,5/ 1,6/ 1					--					2,5			4			6,3			4			6,3			10			6,3			10			16		
	max. diff. pressure <sup>1)</sup>	(bar)	--				40					--					40					40			40			40			40			40			40			40			
Seat-Ø		(mm)	3	5	12	18	3	5	12	18	22	3	5	12	18	22	25	22	25	32	25	32	40	40																			
Travel		(mm)	20				20					20					20			20			20			20			30														
2,2 kN	Closing pressure	I.	(bar)	40				40					40					35,9			40			35,9			21,6			35,2			21,1			13,2							
		II.	(bar)	40				40					40					33,7			40			33,7			20,2			32,1			19,2			11,9							
		III.	(bar)	33,3	33	32	31,1	33,3	33	32	31,1	30,5	31,8	31,5	30,5	29,6	29,1	28,6	29,1	28,6	18	28,6	18	28,6	18	11,2																	
	Operating time (50 Hz)	(s)	53				53					53					53			53			53			53			79														
	Operating speed	(mm/s)	0,38																																								
5 kN	Closing pressure	I.	(bar)															40			40			40			40			34,6													
		II.	(bar)															40			40			40			40			33,4													
		III.	(bar)	40				40					40					40			40			40			40			32,6													
	Operating time (50 Hz)	(s)	53				53					53					53			53			53			53			79														
	Operating speed	(mm/s)	0,38																																								
12 kN	Closing pressure	I.	(bar)																											40													
		II.	(bar)																											40													
		III.	(bar)																											40													
	Operating time (50 Hz)	(s)																											79														
	Operating speed	(mm/s)	0,38																																								

DN			50			65			80			100			125			150													
Parabolic plug	Kvs-value	(m³/h)	16	25	40	25	40	63	40	63	100	63	100	160	100	160	250	160	250	400											
	max. diff. pressure <sup>1)</sup>	(bar)	40	30		30			15	30	15	8	15	8	4	8	4	2	4	2											
V-port plug	Kvs-value	(m³/h)	--			--			63			--			63			100			160			250			400				
	max. diff. pressure <sup>1)</sup>	(bar)	--			--			30			--			30			25			30			25			15			15	
Perforated plug	Kvs-value	(m³/h)	10	16	25	16	25	40	25	40	63	40	63	100	63	100	160	100	160	250	100	160	250								
	max. diff. pressure <sup>1)</sup>	(bar)	40	40		40			40			40			40			40			40			40							
Seat-Ø		(mm)	32	40	50	40	50	65	50	65	80	65	80	100	80	100	125	100	125	150	100	125	150								
Travel		(mm)	20	30		30			30			30			30			30			50			30			50				
2,2 kN	Closing pressure	I.	(bar)	21,1	13,2	8,1	13,2	8,1	4,5	8	4,4	2,7	4,4	2,7	1,5	2,7	1,5		1,5												
		II.	(bar)	19,2	11,9	7,3	11,9	7,3	4	7,1	3,9	2,3	3,9	2,3	1,3	2,3	1,3		1,3												
		III.	(bar)	18	11,2	6,8	11,2	6,8	3,7	6,8	3,7	2,2	3,7	2,2	1,2	1,9	1		1												
	Operating time (50 Hz)	(s)	53	79		79			79			79			79			79			79			79							
	Operating speed	(mm/s)	0,38																												
5 kN	Closing pressure	I.	(bar)	40	34,6	21,9	34,6	21,9	12,7	21,8	12,6	8,2	12,6	8,2	5	8,2	5	3,1	5	3,1	2										
		II.	(bar)	40	33,4	21,1	33,4	21,1	12,2	20,9	12,1	7,8	12,1	7,8	4,8	7,8	4,8	2,9	4,8	2,9	1,9										
		III.	(bar)	40	32,6	20,6	32,6	20,6	11,9	20,6	11,9	7,7	11,9	7,7	4,7	7,4	4,5	2,8	4,5	2,8	1,8										
	Operating time (50 Hz)	(s)	53	79		79			79			79			79			79			132			132							
	Operating speed	(mm/s)	0,38																												
12 kN	Closing pressure	I.	(bar)		40		40	33,3	40	33,2	21,8	33,2	21,8	13,8	21,8	13,8	8,7	13,8	8,7	5,9											
		II.	(bar)		40		40	32,8	40	32,7	21,5	32,7	21,5	13,6	21,5	13,6	8,6	13,6	8,6	5,8											
		III.	(bar)		40		40	32,5	40	32,5	21,3	32,5	21,3	13,5	21	13,3	8,4	13,3	8,4	5,7											
	Operating time (50 Hz)	(s)		79		79	79			79			79			79			132			132									
	Operating speed	(mm/s)	0,38																												
15 kN	Closing pressure	I.	(bar)				40		40	27,7	40	27,7	17,6	27,7	17,6	11,1	17,6	11,1	7,6												
		II.	(bar)				40		40	27,3	40	27,3	17,3	27,3	17,3	11	17,3	11	7,5												
		III.	(bar)				40		40	27,2	40	27,2	17,3	26,9	17,1	10,8	17,1	10,8	7,4												
	Operating time (50 Hz)	(s)				79		79	79			79			79			132			132										
	Operating speed	(mm/s)	0,38																												

- I. Fig. 470: PTFE-V-ring unit / EPDM-sealing
- II. Fig. 470: PTFE- / pure graphite-packing
- III. Fig. 471: Bellows seal

<sup>1)</sup> max. differential pressure drop

Control valve in straightway form with electric actuator PREMIO-Plus 2G

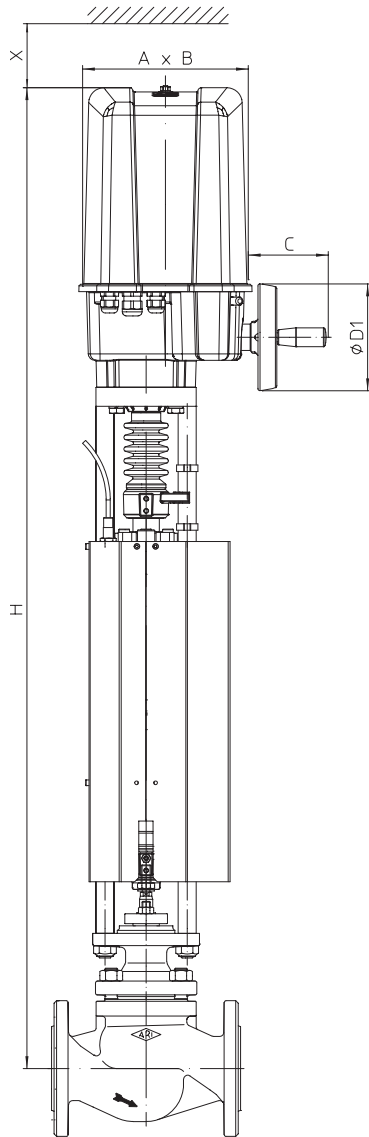


Fig. 470

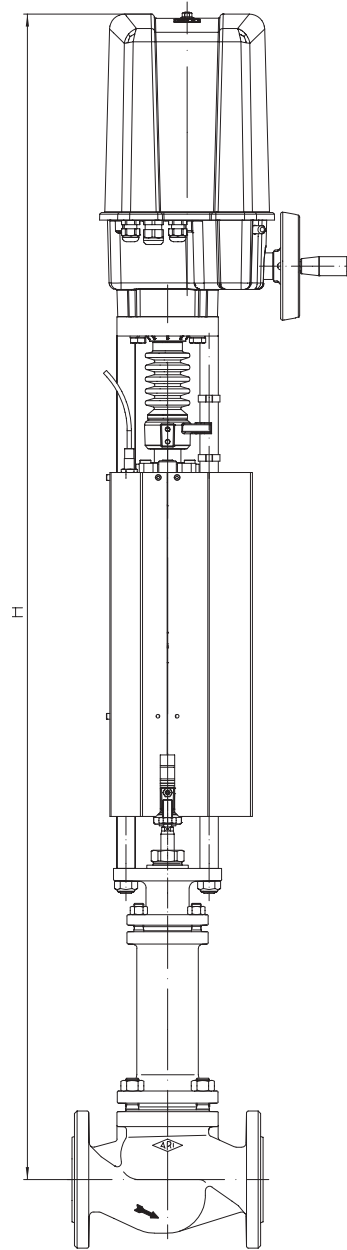


Fig. 471

Actuator data		9 kN
A	(mm)	210
B	(mm)	184
C	(mm)	90
Ø D1	(mm)	130
X	(mm)	200
<b>Motor voltage:</b> 24V AC/DC <b>Other voltages:</b> 90-264V AC 47-63Hz, 127-370V DC <b>Further technical data of the actuator:</b> refer to data sheet ARI-PREMIO-Plus 2G with fail-safe function		

Heights and weights

DN		40	50	65	80	100	125	150		
Fig. 470	9 kN	H	(mm)	1194	1194	1190	1223	1225	1280	1285
		PN16 / 25	(kg)	42	44	48	58	72	93	117
		PN40	(kg)	44	46	51	63	79	101	127
Fig. 471	9 kN	H	(mm)	1405	1405	1414	1423	1453	1606	1612
		PN16 / 25	(kg)	45	47	57	65	80	107	134
		PN40	(kg)	46	48	59	68	84	117	141

Further dimensions refer to pages 20-23.



max. permissible closing pressures on flow-to-open P2 = 0.  
Observe pressure-temperature-limits, refer to page 2.

DN			40			50			65			80		
Parabolic plug	Kvs-value	(m <sup>3</sup> /h)	10	16	25	16	25	40	25	40	63	40	63	100
	max. diff. pressure <sup>1)</sup>	(bar)	40		30	40	30		30		15	30	15	8
V-port plug	Kvs-value	(m <sup>3</sup> /h)	--			--			--		63	--	63	100
	max. diff. pressure <sup>1)</sup>	(bar)	--			--			--		30	--	30	
Perforated plug	Kvs-value	(m <sup>3</sup> /h)	6,3	10	16	10	16	25	16	25	40	25	40	63
	max. diff. pressure <sup>1)</sup>	(bar)	40			40	40		40			40		
Seat-Ø		(mm)	25	32	40	32	40	50	40	50	65	50	65	80
Travel		(mm)	20		30	20	30		30			30		
9 kN	Closing pressure	I. (bar)	40			40			40		24,5	40	24,4	16
		II. (bar)	40			40			40		24	40	23,9	15,6
		III. (bar)	40			40			40		23,7	40	23,7	15,5
	Operating time (50 Hz)		(s)	53		79	53	79		79		79		
	Operating speed		(mm/s)	0,38										
	Operating time on electrical power failure		(s)	1										
	Operating speed on electrical power failure		(mm/s)	100										

DN			100			125			150			
Parabolic plug	Kvs-value	(m <sup>3</sup> /h)	63	100	160	100	160	250	160	250	400	
	max. diff. pressure <sup>1)</sup>	(bar)	15	8	4	8	4	2	4	2		
V-port plug	Kvs-value	(m <sup>3</sup> /h)	63	100	160	100	160	250	160	250	400	
	max. diff. pressure <sup>1)</sup>	(bar)	30		25	30	25	15	25	15		
Perforated plug	Kvs-value	(m <sup>3</sup> /h)	40	63	100	63	100	160	100	160	250	
	max. diff. pressure <sup>1)</sup>	(bar)	40			40			40			
Seat-Ø		(mm)	65	80	100	80	100	125	100	125	150	
Travel		(mm)	30			30		50	30	50		
9 kN	Closing pressure	I. (bar)	24,4	16	10,1	16	10,1	6,3	10,1	6,3	4,3	
		II. (bar)	23,9	15,6	9,8	15,6	9,8	6,1	9,8	6,1	4,2	
		III. (bar)	23,7	15,5	9,7	15,2	9,6	6	9,6	6	4	
	Operating time (50 Hz)		(s)	79			79		132	79	132	
	Operating speed		(mm/s)	0,38								
	Operating time on electrical power failure		(s)	1								
	Operating speed on electrical power failure		(mm/s)	100								

- I. Fig. 470: PTFE-V-ring unit / EPDM-sealing  
 II. Fig. 470: PTFE- / pure graphite-packing  
 III. Fig. 471: Bellows seal

<sup>1)</sup> max. differential pressure drop

## Control valve in straightway form with electric actuator AUMA

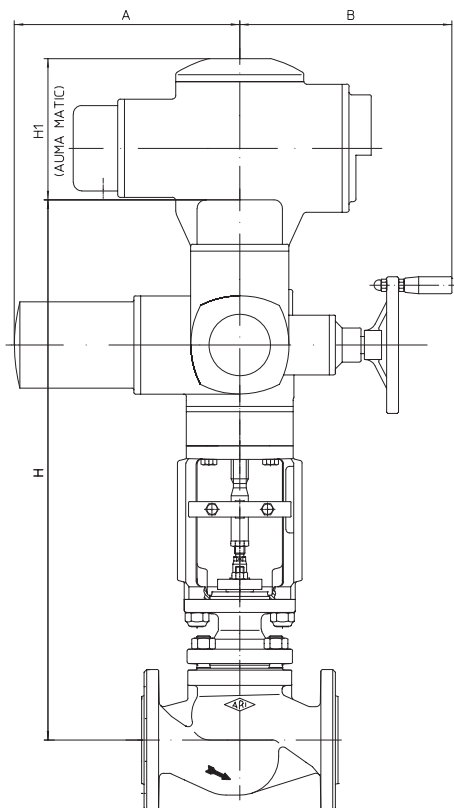


Fig. 470

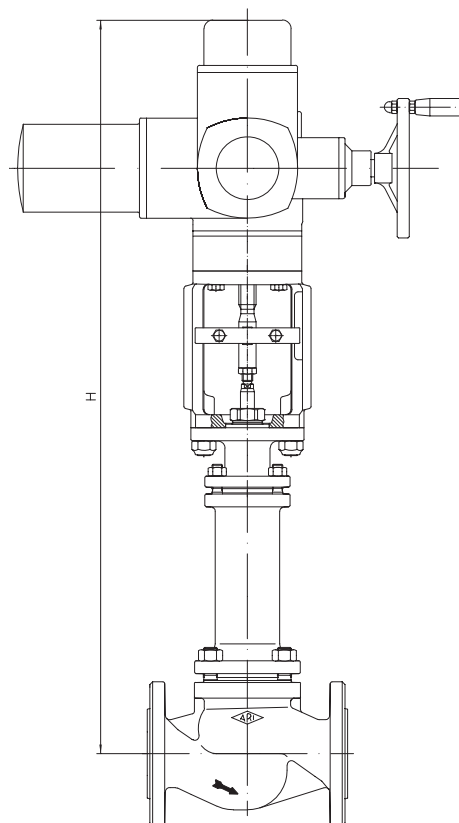


Fig. 471

Actuator data		SAR 07.2	SAR 07.6	SAR 10.2	SAR 14.2	SAR 14.6
A	(mm)	265		283	389	
B	(mm)	249		254	336	339
H1 (AUMA MATIC)	(mm)	130			182	

Motor voltage: 400V 50Hz 3~ (Other voltages on request)  
 Technical data for actuator refer to price list.

## Heights and weights

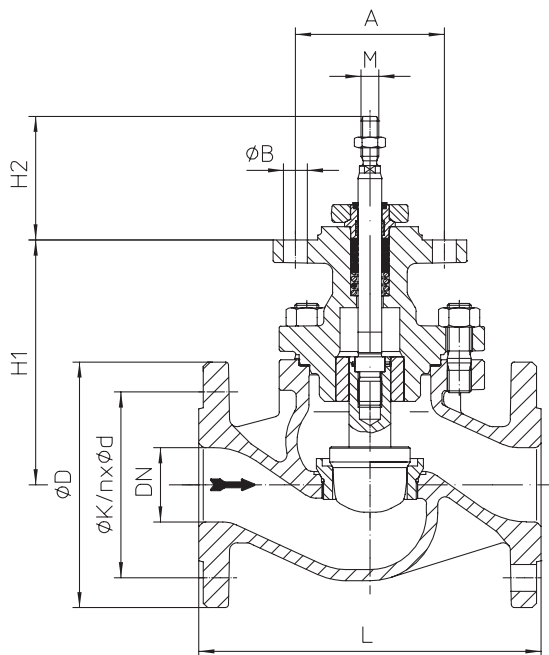
DN		25	32	40	50	65	80	100	125	150		
Fig. 470	SAR 07.2 SAR 07.6	H	(mm)	652	652	683	683	679	712	714	769	774
		PN16 / 25	(kg)	37	39	44	45	50	60	74	95	119
		PN40	(kg)	38	40	45	47	53	64	80	103	129
	SAR 10.2	H	(mm)	--	--	--	--	--	714	716	771	776
		PN16 / 25	(kg)	--	--	--	--	--	62	76	97	121
		PN40	(kg)	--	--	--	--	--	67	83	105	131
	SAR 14.2	H	(mm)	--	--	--	--	--	--	--	839	869
		PN16 / 25	(kg)	--	--	--	--	--	--	--	140	172
		PN40	(kg)	--	--	--	--	--	--	--	147	182
	SAR 14.6 LE100	H	(mm)	--	--	--	--	--	--	--	1097	1127
		PN16 / 25	(kg)	--	--	--	--	--	--	--	186	218
		PN40	(kg)	--	--	--	--	--	--	--	193	228
Fig. 471	SAR 07.2 SAR 07.6	H	(mm)	809	809	894	894	903	912	942	1095	1101
		PN16 / 25	(kg)	39	41	47	49	59	67	82	109	136
		PN40	(kg)	40	42	47	50	60	69	85	119	143
	SAR 10.2	H	(mm)	--	--	--	--	--	914	944	1097	1103
		PN16 / 25	(kg)	--	--	--	--	--	69	84	111	138
		PN40	(kg)	--	--	--	--	--	72	88	121	145
	SAR 14.2	H	(mm)	--	--	--	--	--	--	--	1398	1428
		PN16 / 25	(kg)	--	--	--	--	--	--	--	173	204
		PN40	(kg)	--	--	--	--	--	--	--	180	215

For version with AUMA SAR Ex other heights.

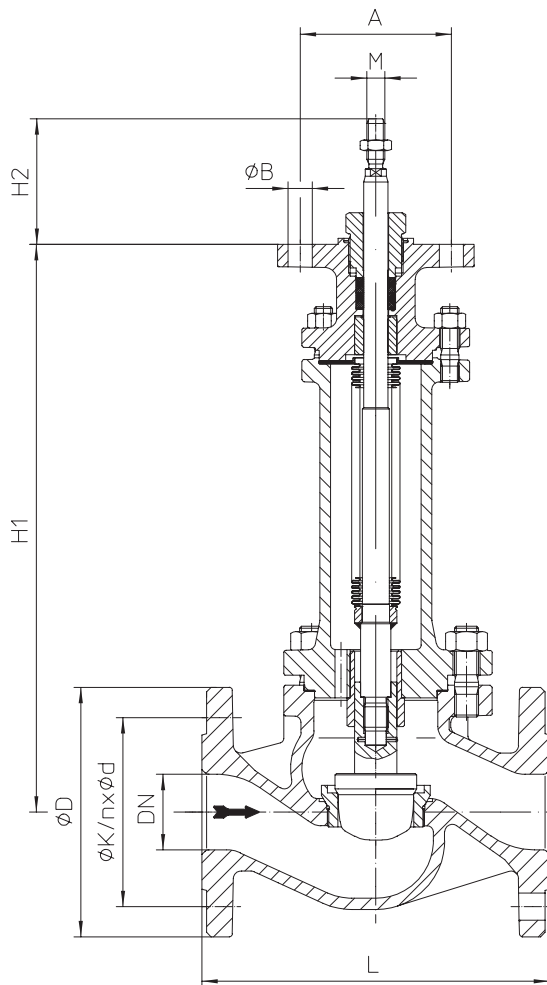
Further dimensions refer to pages 20-23.



## Control valve in straightway form with flanges


**Fig. 470....1**
**DN15-150**

(e.g.: DP32-34; PREMIO 2,2-15kN; AUMA 07.2-10.2)


**Fig. 471....1**
**DN15-150**

(e.g.: DP32-34; PREMIO 2,2-15kN; AUMA 07.2-10.2)

DN	15	20	25	32	40	50	65	80	100	125	150
----	----	----	----	----	----	----	----	----	-----	-----	-----

Dimensions			M10				M12			M16 x 1,5				
M	Fig. 470	(mm)												
	Fig. 471	(mm)												
H1	Fig. 470	(mm)	131	131	134	134	165	165	161	194	196	251	256	
	Fig. 471	(mm)	288	288	291	291	376	376	385	394	424	577	583	
H2	Fig. 470 / 471	(mm)							83					
A	Fig. 470 / 471	(mm)							100					
ØB	Fig. 470 / 471	(mm)							16					

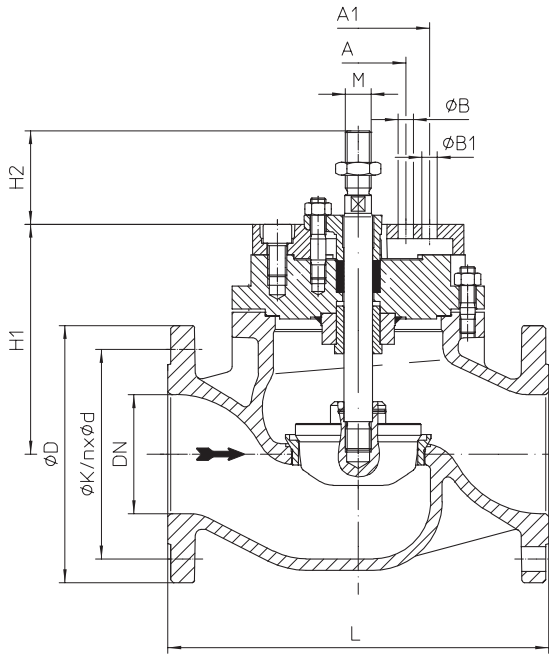
Face-to-face dimension FTF series 1 according to DIN EN 558			130	150	160	180	200	230	290	310	350	400	480
L	(mm)												

Flanges acc. to DIN EN 1092-1/2		Flange holes / -thickness tolerances acc. to DIN 2533/2544/2545											
ØD	PN16	(mm)	95	105	115	140	150	165	185	200	220	250	285
	PN25 / 40	(mm)									235	270	300
ØK	PN16	(mm)	65	75	85	100	110	125	145	160	180	210	240
	PN25 / 40	(mm)									190	220	250
n x Ød	PN16	(mm)	4 x 14				4 x 18			8 x 18		8 x 22	
	PN25 / 40	(mm)	4 x 14				4 x 18			8 x 18	8 x 22	8 x 26	

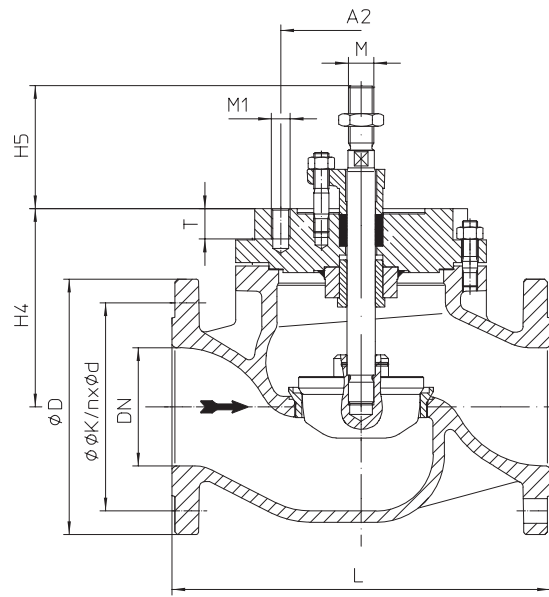
Weights			7	8	9	10	15	17	21	31	45	66	90
Fig. 470	PN16 / 25	(kg)											
	PN40	(kg)	7	9	10	12	17	19	24	36	52	74	100
Fig. 471	PN16 / 25	(kg)	9	10	10	12	18	20	30	38	53	80	107
	PN40	(kg)	10	11	11	13	19	21	32	41	57	90	114

max. permissible thrust			12,7	18,2	40,6
Fig. 470	(kN)				
Fig. 471	(kN)		18,2	29,6	40,6

## Control valve in straightway form with flanges

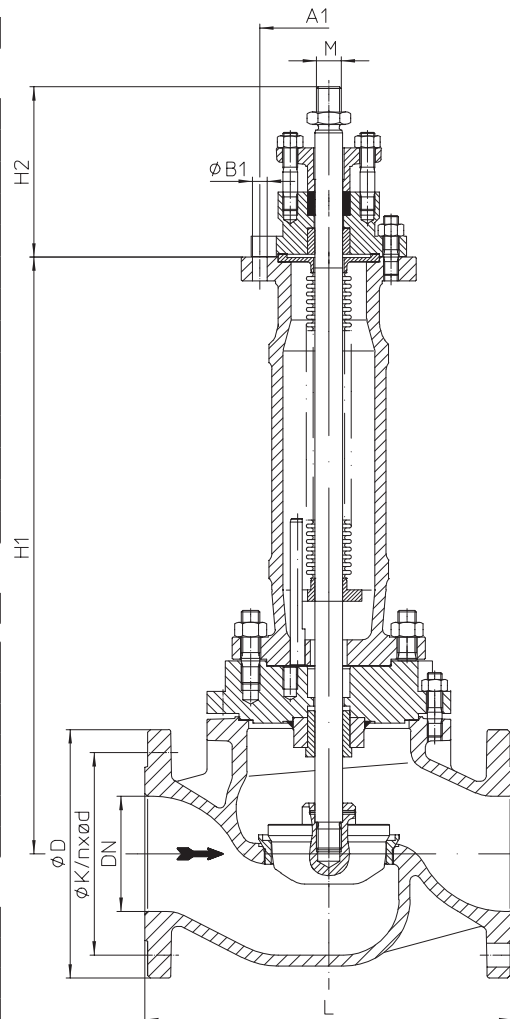


**Fig. 470....1**  
 DN125-150  
 (e.g.: DP34T-34Tri)



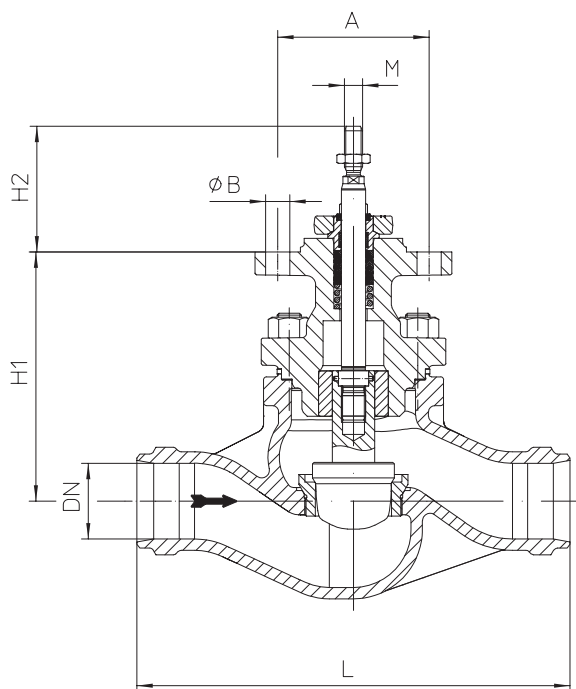
**Fig. 470....1**  
 DN125-150  
 (e.g.: DP35; AUMA 14.2-14.6)

DN	125	150
<b>Dimensions</b>		
M	Fig. 470 / 471 (mm)	M27
H1	Fig. 470 (mm)	242
	Fig. 471 (mm)	649
H2	Fig. 470 (mm)	98
	Fig. 471 (mm)	185
H4	Fig. 470 (mm)	210
H5	Fig. 470 (mm)	130
A	Fig. 470 (mm)	100
n x ØB	Fig. 470 (mm)	2 x 16
A1	Fig. 470 / 471 (mm)	150
n x ØB1	Fig. 470 / 471 (mm)	4 x 16
A2	Fig. 470 (mm)	170
n x M1	Fig. 470 (mm)	8 x M20
T	Fig. 470 (mm)	32
<b>Face-to-face dimension FTF series 1 according to DIN EN 558</b>		
L	(mm)	400
<b>Flanges acc. to DIN EN 1092-1/-2</b>		
ØD	PN16 (mm)	250
	PN25 / 40 (mm)	270
ØK	PN16 (mm)	210
	PN25 / 40 (mm)	220
n x Ød	PN16 (mm)	8 x 18
	PN25 / 40 (mm)	8 x 26
<b>Weights</b>		
Fig. 470	PN16 / 25 (kg)	74
	PN40 (kg)	81
Fig. 471	PN16 / 25 (kg)	107
	PN40 (kg)	114
<b>max. permissible thrust</b>		
Fig. 470	(kN)	112
Fig. 471	(kN)	70

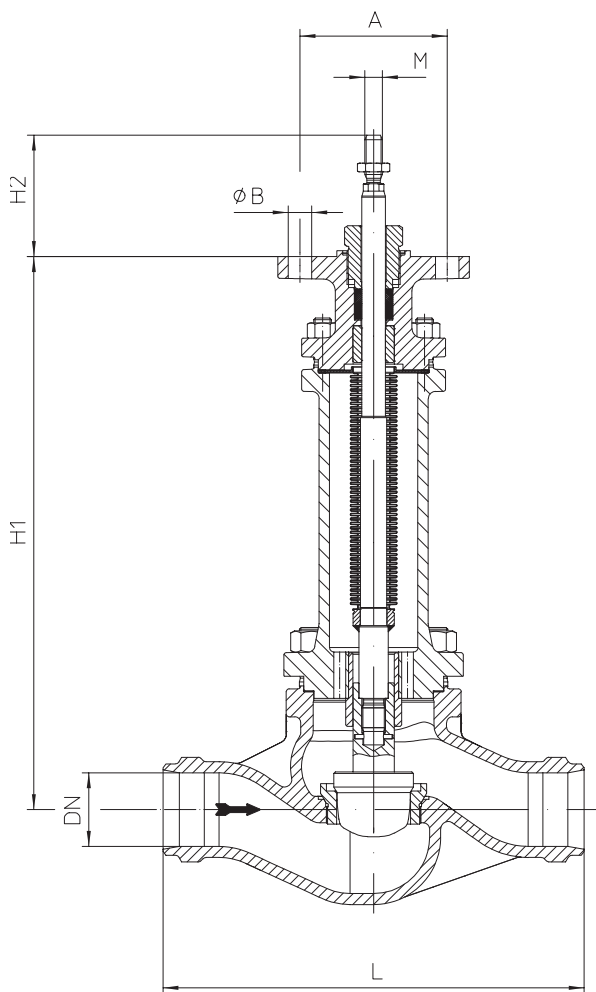


**Fig. 471....1**  
 DN125-150  
 (e.g.: DP34T-35; AUMA 14.2)

## Control valve in straightway form with butt weld ends


**Fig. 470...4**
**DN25-150**

(e.g.: DP32-34; PREMIO 2,2-15kN; AUMA 07.2-10.2)


**Fig. 471...4**
**DN25-150**

(e.g.: DP32-34; PREMIO 2,2-15kN; AUMA 07.2-10.2)

DN	25	40	50	80	100	150
----	----	----	----	----	-----	-----

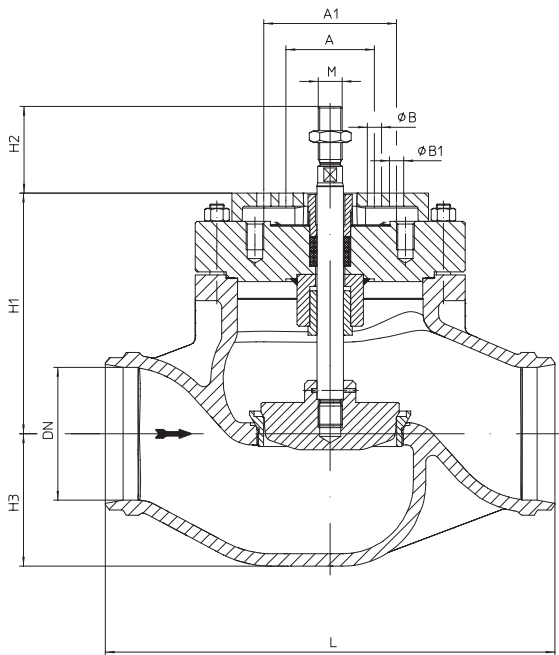
Dimensions							
M	Fig. 470	(mm)	M10	M12		M16 x 1,5	
	Fig. 471	(mm)	M12		M14 x 1,5		
H1	Fig. 470	(mm)	134	165	165	194	196
	Fig. 471	(mm)	291	376	376	394	424
H2	Fig. 470 / 471	(mm)	83				
A	Fig. 470 / 471	(mm)	100				
ØB	Fig. 470 / 471	(mm)	16				

Face-to-face dimension ETE series 73 according to DIN EN 12982							
L	(mm)	210	251	286	337	394	508
Butt weld ends acc. to DIN EN 12627 Fig. 4 (refer to page 26)							

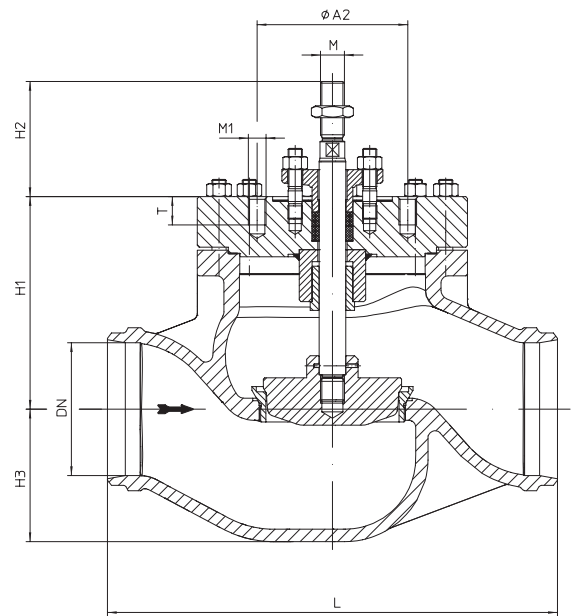
Weights							
Fig. 470	PN40	(kg)	8	14	15	28	43
Fig. 471	PN40	(kg)	9	16	17	33	48

max. permissible thrust							
Fig. 470	(kN)	12,7	18,2		40,6		
Fig. 471	(kN)	18,2		29,6		40,6	

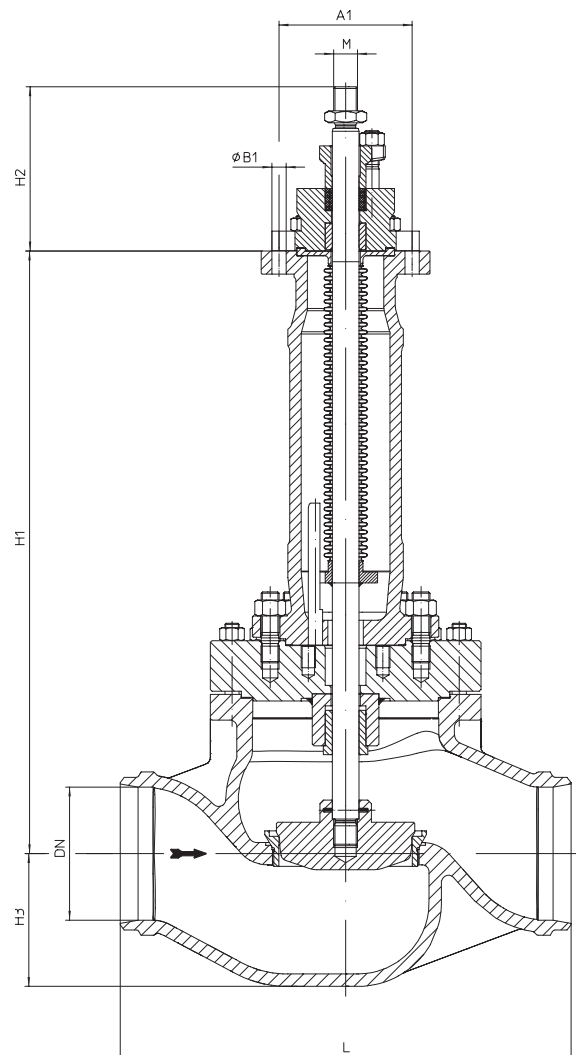
Control valve in straightway form with butt weld ends



**Fig. 470...4**  
 DN150  
 (e.g.: DP34T-34Tri)



**Fig. 470...4**  
 DN150  
 (e.g.: DP35; AUMA 14.2-14.6)



**Fig. 471...4**  
 DN150  
 (e.g.: DP34T-35; AUMA 14.2)

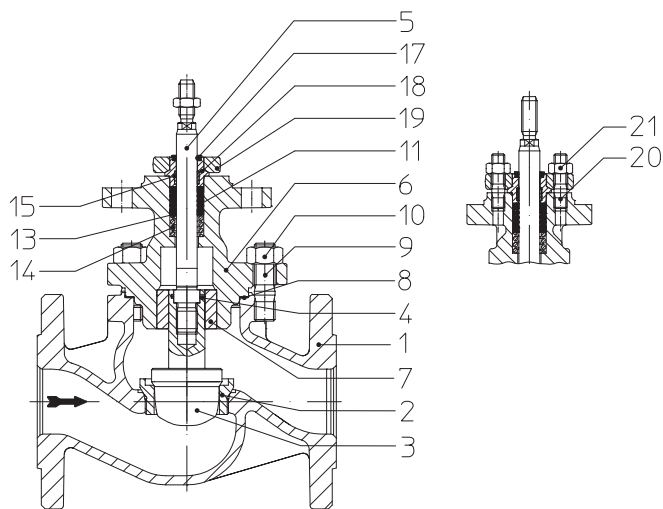
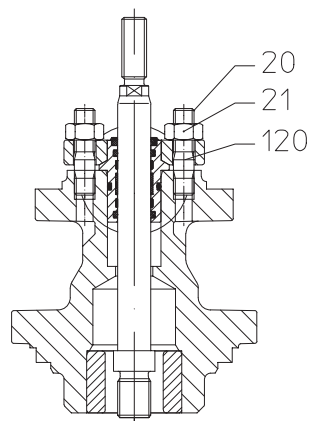
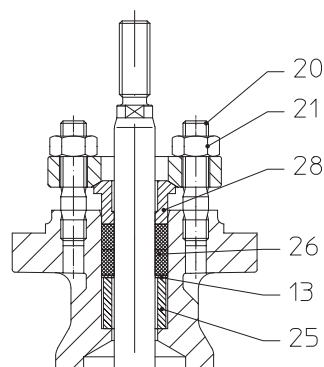
<b>DN</b>	<b>150</b>		
-----------	------------	--	--

Dimensions			
M	Fig. 470 / 471	(mm)	M27
H1	Fig. 470	(mm)	272
	Fig. 471	(mm)	679
H2	Fig. 470	(mm)	98
	Fig. 471	(mm)	185
H4	Fig. 470	(mm)	240
H5	Fig. 470	(mm)	130
A	Fig. 470	(mm)	100
n x ØB	Fig. 470	(mm)	2 x 16
A1	Fig. 470 / 471	(mm)	150
n x ØB1	Fig. 470 / 471	(mm)	4 x 16
A2	Fig. 470	(mm)	170
n x M1	Fig. 470	(mm)	8 x M20
T	Fig. 470	(mm)	32

Face-to-face dimension ETE series 73 according to DIN EN 12982		
L	(mm)	508
Butt weld ends acc. to DIN EN 12627 Fig. 4 (refer to page 26)		

Weights			
Fig. 470	PN40	(kg)	98
Fig. 471	PN40	(kg)	131

max. permissible thrust			
Fig. 470	(kN)	112	
Fig. 471	(kN)	70	

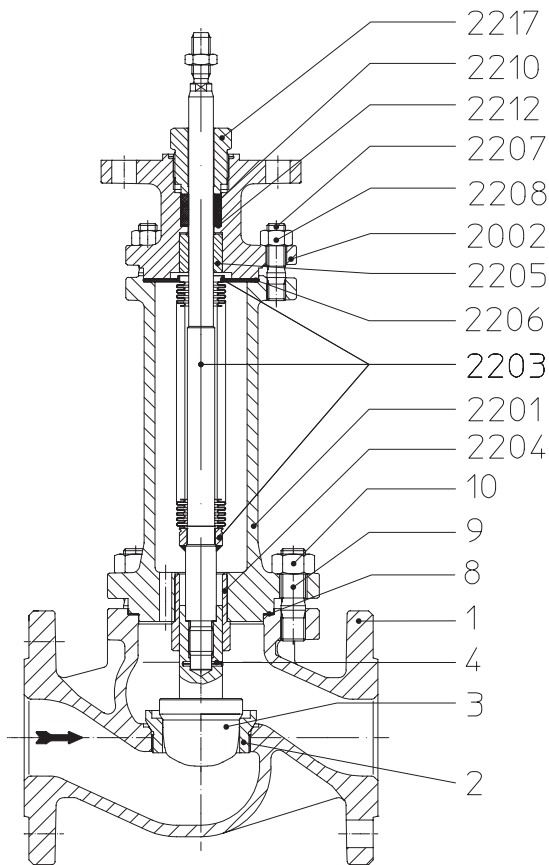

**I. PTFE-V-ring unit**

**I. EPDM-sealing**

**II. PTFE- / pure graphite-packing**

Pos.	Sp.p.	Description	Fig. 12.470	Fig. 22.470 / Fig. 23.470	Fig. 34.470 / Fig. 35.470	Fig. 54.470 / Fig. 55.470
1		Body	EN-GJL-250 , EN-JL1040	EN-GJS-400-18U-LT, EN-JS1049	GP240GH+N, 1.0619+N	GX5CrNiMoN19-11-2, 1.4581
2	x	Seat ring	X20Cr13+QT, 1.4021+QT			X6CrNiMoTi17 12 2, 1.4571
3	x	Plug	X20Cr13+QT, 1.4021+QT			X6CrNiMoTi17 12 2, 1.4571
4	x	Clamping sleeve	X10CrNi18-8, 1.4310			
5	x	Stem	X20Cr13+QT, 1.4021+QT			X6CrNiMoTi17 12 2, 1.4571
6		Mounting bonnet	EN-GJS-400-18U-LT, EN-JS1049		GP240GH+N, 1.0619+N	GX5CrNiMoN19-11-2, 1.4581
7		Guide bushing	X20Cr13+QT, 1.4021+QT (hardened)			X6CrNiMoTi17 12 2, 1.4571
8	x	Gasket	Pure graphite (CrNi laminated with graphite)			
9		Stud	25CrMo4, 1.7218			A4-70
10		Hexagon nuts	C35E, 1.1181			A4
11	Set refer to Pos. 100	V-ring unit	PTFE			
13		Washer	X5CrNi18-10, 1.4301			
14		Compression spring	X10CrNi18-8, 1.4310			
15		Guide bush	PTFE25%C			
17		Scraper	PTFE			
18		Stem guiding	X8CrNiS18-9, 1.4305			
19		Packing box flange	P250GH, 1.0460			X6CrNiMoTi17 12 2, 1.4571
20		Stud	A4-70			
21		Hexagon nuts	A4			
25	x	Distance bush	X20Cr13+QT, 1.4021+QT			X6CrNiMoTi17 12 2, 1.4571
26	x	Packing ring	PTFE or Pure graphite			
28	x	Packing follower	X20Cr13+QT, 1.4021+QT			X6CrNiMoTi17 12 2, 1.4571

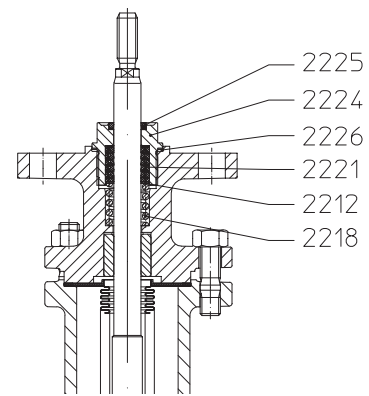
**Stem sealings Fig. 470**

100	x	V-ring unit (set)	Set of Pos. 11, 13, 14, 15, 17, 18		
120	x	EPDM-sealing, cpl.	EPDM / X8CrNiS18-9, 1.4305		
26	x	Packing ring	PTFE		
26	x	Packing ring	Pure graphite		
		L Spare parts			

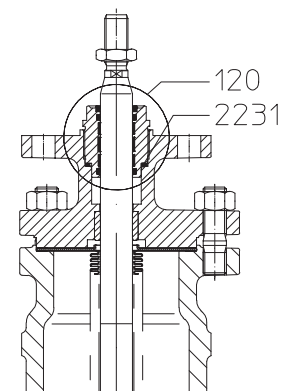




III. Stainless steel-bellow with PTFE-packing / Pure graphite-packing



III. Stainless steel-bellow with V-ring unit



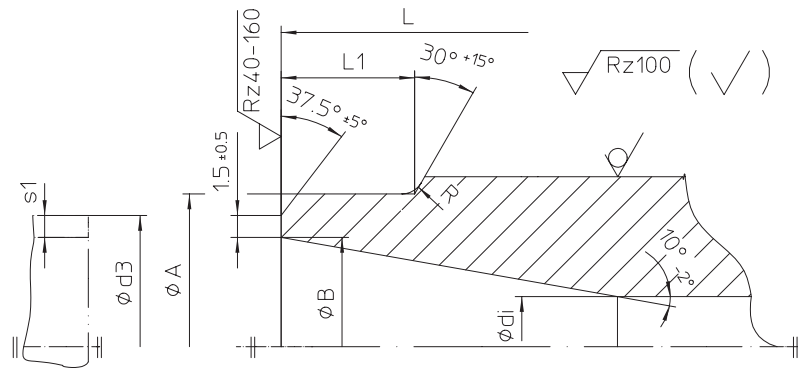
III. Stainless steel bellows seal with EPDM-sealing

Pos.	Sp.p.	Description	Fig. 12.471	Fig. 22.471 / Fig. 23.471	Fig. 34.471 / Fig. 35.471
1		Body	EN-GJL-250, EN-JL1040	EN-GJS-400-18U-LT, EN-JS1049	GP240GH+N, 1.0619+N
2	x	Seat ring	X20Cr13+QT, 1.4021+QT		
3	x	Plug	X20Cr13+QT, 1.4021+QT		
4	x	Clamping sleeve	X10CrNi18-8, 1.4310		
8	x	Gasket	Pure graphite (CrNi laminated with graphite)		
9		Stud	25CrMo4, 1.7218		
10		Hexagon nuts	C35E, 1.1181		
2201		Bellows housing	EN-GJS-400-18U-LT, EN-JS1049		GP240GH+N, 1.0619+N
2202		Mounting bonnet	EN-GJS-400-18U-LT, EN-JS1049		GP240GH+N, 1.0619+N
2203	x	Stem- / Bellows unit	X20Cr13+QT, 1.4021+QT / X6CrNiTi18-10, 1.4541		
2204		Guide bushing	X20Cr13+QT, 1.4021+QT (hardened)		
2205		Guide bushing	X20Cr13+QT, 1.4021+QT (hardened)		
2206	x	Gasket	Pure graphite (CrNi laminated with graphite)		
2207		Stud	25CrMo4, 1.7218		
2208		Hexagon nuts	C35E, 1.1181		
2210	x	Packing ring	Pure graphite or PTFE		
2212	x	Washer	X5CrNi18-10, 1.4301		
2217	x	Coupling	X8CrNiS18-9, 1.4305		
2212	Set: refer to Pos. 100	Washer	X5CrNi18-10, 1.4301		
2218		Compression spring	X10CrNi18-8, 1.4310		
2221		V-ring unit	PTFE		
2224		Coupling	X8CrNiS18-9, 1.4305		
2225		Scraper	PTFE		
2226		Gasket	X6CrNiMoTi17-12-2, 1.4571		
2231	x	Gasket	Cu		

Stem sealings Fig. 471			
2210	x	Packing ring	Pure graphite or PTFE
100	x	V-ring unit (set)	Set of Pos. 2212, 2218, 2221, 2224, 2225, 2226
120	x	EPDM-sealing, cpl.	EPDM / X8CrNiS18-9, 1.4305
		L Spare parts	

L = Face-to-face dimension

Edge shaping acc. to DIN EN 25817



DN	25	40	50	80	100	150
----	----	----	----	----	-----	-----

Butt weld ends acc. to DIN EN 12627								
L	Fig. 470 / 471	(mm)	210	251	286	337	394	508
ØA	Fig. 470 / 471	(mm)	35	50	62	91	117	172
ØB	Fig. 470 / 471	(mm)	28,5	43,1	53,9	80,9	104,3	157,1
Ødi	Fig. 470 / 471	(mm)	25	40	50	80	100	150
R	Fig. 470 / 471	(mm)	3	3	3	3	3	3
L1 (ähnl.)	Fig. 470 / 471	(mm)	10	10	10	12	14	20
Ød3	Fig. 470 / 471	(mm)	33,7	48,3	60,3	88,9	114,3	168,3
s1	Fig. 470 / 471	(mm)	2,6	2,6	3,2	4	5	5,6

Face-to-face dimension ETE series 1 according to DIN EN 12982

Butt weld ends according to DIN EN 12627 Fig. 4

Weld joint according to DIN EN 29692 code number 1.3.3

The material used for ARI valves with butt weld ends are: GP240GH+N, 1.0619+N acc. to DIN EN 10213-2,

Based on our experience we recommend electric welding process for connecting valves or strainers with tubes or with each other.

Lime based electrodes with an appropriate composite material should be used as filler material for welding.

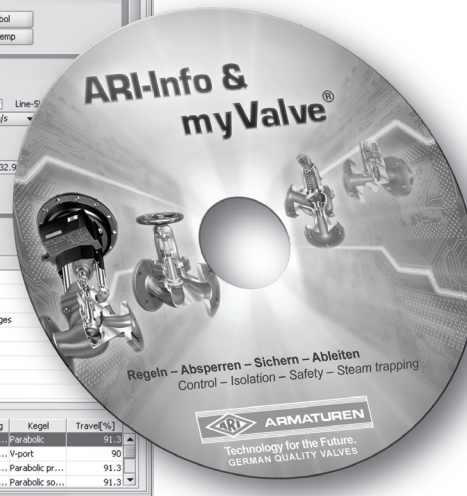
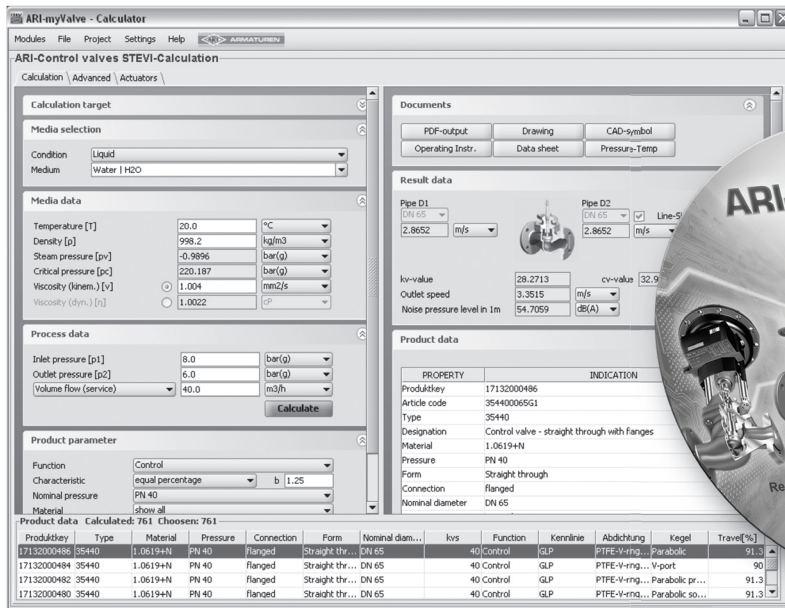
Gas welding should be avoided.

Because of the different material compositions and wall thickness of the steam traps and the pipe gas welding shall not be applied. Quenching cracks and coarse grain structure may develop.



**myValve® - Your Valve Sizing-Program.**

myValve® is a powerful software tool that not only helps you size your system components; it also gives you instant access to all other data about the selected product, such as order information, spare parts drawings, operating instructions, data sheets, etc., whenever you need it.


**Contents:**
**Module ARI-control valves STEVI-calculation**

- Sizing (calculation of flow quantity Kv, volume flow Q, pressure drop  $\Delta p$ , sound level and selecting the valve.)

**Media:**
**Integrated media-data bank (more than 160 media) with conditions:**

- Vapours / gases
- Steam (saturated and superheated)
- Liquids

**Special features:**

- Project administration of the calculation and product data incl. spare part drawings concerning to project and tag number.
- Direct output or calculation and product data in PDF format.
- Product data could be taken for a direct order.
- SI- and ANSI-units with direct conversion to another data bank.
- Settings with over pressure or absolute pressure.
- All ARI valves are integrated in a data bank.
- Direct access concerning to the product on data sheets, operating instructions, pressure-temperature-diagram and spare part drawings
- Operation in company networks possible (no complex installations on individually PC's necessary).
- Extensive catalogue extending over several product groups.

**System Requirements:**

Windows operating systems, Linux, etc.



**Technology for the Future.**  
**GERMAN QUALITY VALVES**

ARI-Armaturen Albert Richter GmbH & Co. KG, D-33756 Schloß Holte-Stukenbrock,  
 Tel. +49 52 07 / 994-0, Telefax +49 52 07 / 994-158 or 159 Internet: <http://www.ari-armaturen.com> E-mail: [info.vertrieb@ari-armaturen.com](mailto:info.vertrieb@ari-armaturen.com)